

TM 9-4910-420-12

DEPARTMENT OF THE ARMY TECHNICAL MANUAL

OPERATOR AND ORGANIZATIONAL
MAINTENANCE MANUAL
(INCLUDING REPAIR PARTS AND
SPECIAL TOOL LISTS)

TESTER, ENGINE DISTRIBUTOR.
BENCH-TYPE, 6,12, AND 24-VOLT
DISTRIBUTORS, SINGLE-PHASE
60-CYCLE, 115-VOLT (HEYER
PRODUCTS COMPANY INC.,
MODEL 168) (4910-392-2939)

This copy is a reprint which includes current
pages from Change 1

HEADQUARTERS, DEPARTMENT OF THE ARMY
30 SEPTEMBER 1963

Change }
 No. 1 }

HEADQUARTERS
 DEPARTMENT OF THE ARMY
 Washington, DC, 29 June 1973

**Operator and Organizational Maintenance
 Manual
 (Including Repair Parts and Special Tool Lists)
 TESTER, ENGINE DISTRIBUTOR, BENCH-TYPE,
 6,12, AND 24-VOLT DISTRIBUTORS, SINGLE-PHASE
 60-CYCLE, 115-VOLT (HEYER PRODUCTS COMPANY
 INC., MODEL 168)
 (4910-392-2939)**

TM 9-4910-420-12, 30 September 1963, is changed as follows

Page 34. Add the following paragraphs

**Reporting of Equipment Publication
 Improvements**

The reporting of errors, omissions, and recommendations for improving this publication by the individual user is encouraged. Reports should be submitted on DA Form 2028 (Recommended Changes to Publications and forwarded

direct to Commander, US Army Weapons Command, ATTN: AMSWE-MAP-SP, Rock Island, IL 61201.

Components of the End item

Parts included with the end item and considered as components of the end item configuration are listed in the following table:

Table V. Components of the End Item

Components	Part No.	(FSCM)	Qty
ADAPTER, ENGINE ELECTRICAL TEST, PRIMARY CIRCUIT:	600150	(01216)	1
CHUCK, DRIVE:	26043	(28500)	1
CLAMP, DISTRIBUTOR:	26055	(28500)	1
COLLET AND BUSHING SET:	26177	(28500)	1
COLUMN, DRIVE:	26143-1	(28500)	1
COUPLING, DRIVE:	20400	(28500)	1
KIT, ADAPTER, VACUUM:	21197	(28500)	1
TESTER, SPRING RESILIENCY:	MIL-T-43560	(81349)	1
WIRE, JUMPER:	24323	(28500)	1
WORK LAMP ASSEMBLY:	31083	(28500)	1
WRENCH, CHUCK:	31096	(28500)	1

APPENDIX III BASIC ISSUE ITEMS LIST AND ITEMS TROOP INSTALLED OR AUTHORIZED LIST

Section I. INTRODUCTION

1. Scope

This appendix lists basic issue items and items troop installed or authorized required by the crew/operator for operation of the TESTER, ENGINE DISTRIBUTOR.

2. General

This Basic Issue Items List and Items Troop In-

stalled or Authorized List is divided into the following sections:

a. Basic Issue Items List-Section II. A list in alphabetical sequence of items which are furnished with, and must be turned in with, the end item,

b. Items Troop Installed or Authorized List. Not applicable.

Section II. BASIC ISSUE ITEMS LIST

(1) Federal stock No.	(2) Description	(3) Unit of meas	(4) Qty furn with equip	(5) Illustration	
				(a) Fig. No.	(b) Item No
5120-242-7410	KEY, SOCKET HEAD SCREW: hex, L-hdl, 3/32 across fl, 2 nom arm lg	EA	1	16	
5120-240-5292	KEY, SOCKET HEAD SCREW: hex type, 1/8 across fl, L-type hdl, 2 nom lg arm lg	EA	1	16	
5120-198-5392	KEY, SOCKET HEAD SCREW: hex type, 5/32 across fl, L-type hdl, 2-1/2 nom lg arm	EA	1	16	

By Order of the Secretary of the Army:

Official:

VERNE L. BOWERS
Major General, United States Army
The Adjutant General

CREIGHTON W. ABRAMS
General, United States Army
Chief of Staff

Distribution:

Active Army: To be distributed in accordance with DA Form 12-38, (qty rqr block No. 250), Organizational maintenance requirements for Truck, Utility 1/4-Ton, M151, and DA Form 12-40, (qty rqr block no. 136) Organizational maintenance requirements for Rifle, 5.56 MM, M16, M16A1.

NG: State AG (3)

USAR: None.

Technical Manual
No. 9-4910-420-12



HEADQUARTERS,
 DEPARTMENT OF THE ARMY
 WASHINGTON, D.C., 30 September 1963

**TESTER, ENGINE DISTRIBUTOR, BENCH-TYPE
 6, 12, AND 24-VOLT DISTRIBUTORS, SINGLE-PHASE
 60-CYCLE, 115 VOLT (HEYER PRODUCTS COMPANY
 INC., MODEL 168) (4910-392-2939)**

	Paragraph	Page
CHAPTER 1. INTRODUCTION		
Section I. General	1-3	2
II. Description and data	4-7	3,4
CHAPTER 2. OPERATING INSTRUCTIONS		
Section I. Service upon receipt of materiel	8,9	5
II. Control and instruments.	10-26	8,9
III. Operation	27-35	9-16
CHAPTER 3. OPERATOR MAINTENANCE INSTRUCTIONS		
Section I. Repair parts, tools, and equipment	36-39	18
II. Preventive-maintenance services	40-46	18-20
III. Troubleshooting	47-49	21
CHAPTER 4. ORGANIZATIONAL MAINTENANCE INSTRUCTIONS		
Section I. Repair parts, tools, and equipment	50-53	23
II. Lubrication and printing	54,55	23
III. Preventive-maintenance services.	56-59	25,26
IV. Troubleshooting.	60-62	26
V. Electrical clips and electrical cable nipples	63,64	27
VI. Work lamp	65,66	28
VII. Vacuum pump	67,68	28
CHAPTER 5. SHIPMENT AND ADMINISTRATIVE STORAGE AND DEMOLITION TO PREVENT ENEMY USE		
Section I. Shipment and administrative storage	69-71	30
II. Demolition to prevent enemy use	72,73	31
APPENDIX I. REFERENCES		33
APPENDIX II. BASIC ISSUE ITEMS LIST		
Section I. Preface		35
II. Basic issue items list		37
APPENDIX III. MAINTENANCE ALLOCATION CHART		39
APPENDIX IV. REPAIR PARTS AND SPECIAL TOOL LISTS		
Section I. Preface		40
II. Repair parts and special tools.		43
INDEX		45

CHAPTER 1

INTRODUCTION

Section I. GENERAL

1. Scope

a. This technical manual contains instructions on operation and maintenance of the distributor tester for the operator and instructions for organizational maintenance of the distributor tester by personnel of the using organization.

b. Appendix I contains a list of current references, including supply manuals, forms, technical manuals and other available publications applicable to the distributor tester.

c. Appendix II contains the basic issue items which are required by first-echelon maintenance and includes accessories, attachments, component assemblies, and subassemblies with quantities thereof, which constitute the major end item of equipment; and the first echelon maintenance accessories, tools, supplies, and spare assemblies and parts accompanying the equipment, all of which constitute the major end item for issue to users.

d. Appendix III contains the maintenance allocation chart for the tester listing all maintenance and repair operations authorized for all maintenance echelons.

e. Appendix IV contains a list of repair parts which are required by the using organization for performing organizational maintenance on the distributor tester.

f. The direct reporting of errors, omissions and recommendations for improving this equipment manual by the individual user, is authorized and encouraged. DA Form 2028 will be used for reporting these improvements. This form may be completed using pencil, pen or typewriter. DA Form 2028 will be completed in triplicate and forwarded by the individual using the manual. The original and one copy will be forwarded direct to:

Commanding General
Headquarters, U. S. Army Weapons
Command

ATTN: AMSWE-SMM-TE
Rock Island Arsenal
Rock Island, Illinois 61202

One information copy will be provided to the individual's immediate supervisor (e. g., officer, noncommissioned officer, supervisor, etc.)

2. Maintenance Allocation

a. *Operator Maintenance Allocation.* The prescribed maintenance to be performed by the operator will apply as reflected in the operator-maintenance (first echelon) column of the maintenance allocation chart (app. III). In all cases, where the nature of the repair, modification, or adjustment is beyond the scope or facilities of the operator, organizational-maintenance should be informed so that trained personnel with suitable tools and equipment may be provided or other instructions issued.

b. *Organizational Maintenance Allocation.* The prescribed maintenance to be performed by maintenance personnel of the using organization will apply as reflected in the organizational-maintenance (second echelon) column of the maintenance allocation chart (app. III). In all cases, where the nature of the repair, modification, or adjustment is beyond the scope or facilities of the using organization, the supporting maintenance unit should be informed so that trained personnel with suitable tools and equipment may be provided or other instructions issued.

3. Forms, Records, and Reports

a. *General.* Responsibility for the proper execution of forms, records, and reports rests upon the officers of all units maintaining this equipment. However, the value of accurate records must be fully appreciated by all persons responsible for

their compilation, maintenance, and use. Records, reports, and authorized forms are normally utilized to indicate the type, quantity, and condition of materiel to be inspected, to be repaired, or to be used in repairs. Properly executed forms convey authorization and serve as records for replacement of materiel in the hands of troops and for delivery of materiel requiring further repair to shops in arsenals, depots, etc. The forms, records, and reports establish the work required, the progress of the work within shops, and the status of the materiel upon completion of its repair.

b. *Authorized Forms.* The forms gen-

erally applicable to the units operating or maintaining this materiel are listed in appendix I. For a listing of all forms, refer to DA Pam 310-2.

c. *Equipment Improvement Recommendations.* Deficiencies detected in the equipment or materiel should be reported using the Equipment Improvement Recommendation section of DA Form 2407.

d. *Field Report of Accidents.* The reports necessary to comply with the requirements of the Army safety program are prescribed in detail in AR 385-40. These reports are required whenever accidents involving injury to personnel or damage to materiel occur.

Section II. DESCRIPTION AND DATA

4. Description

The distributor tester (fig. 1) is an electrically operated device for testing battery ignition distributors removed from the engine. It is used to determine whether a distributor meets specified tolerances required for satisfactory operation when installed on the engine. The distributor under test is driven by a variable speed device consisting of a cone, movable idler, and disk. Manifold vacuum is simulated by an electrically driven vacuum pump. A stroboscope is provided for accurately checking cam angle, spark advance (vacuum and mechanical) and cam lobe accuracy of both single and dual breaker point distributors having either clockwise or counterclockwise rotation. A tachometer is provided to register revolutions per minute of the distributor shaft. A hinged cover protects the controls and instruments of the tester. The tester is primarily designed for testing the following distributors:

Delco-Remy DR1110159
Delco-Remy DR1110170
Delco-Remy DR1110174
Delco-Remy DR1110184
Delco-Remy DR1110611
Delco-Remy DR1111556
Delco-Remy DR1111561
Delco-Remy DR1111565
Delco-Remy DR1111605
Auto-Lite 1AC4003
Auto-Lite 1AU4005UT

Auto-Lite 1AU4006UT
Auto-Lite 1GC4902A

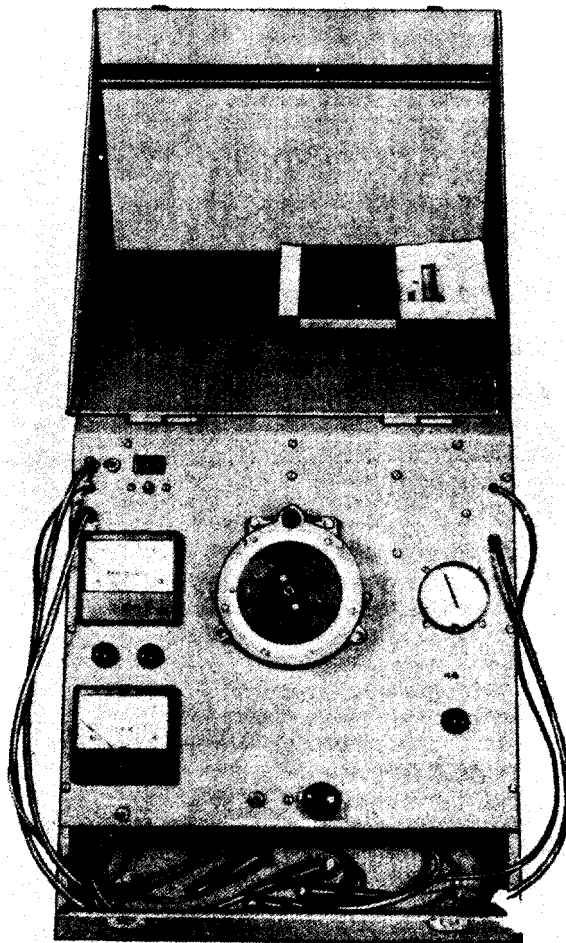

ORD F6119

Figure 1. Distributor tester.

5. Cautions and Identifying Markings

All cautions and identifying markings are printed directly on the panel or on dial faces, and are self-explanatory.

6. Data Plate

The tester data plate (fig. 2) is located on the outside of the case above the hinged cover. The data plate indicates the manufacturer's name and model number, serial number, military specification, and the Federal stock number.

7. Tabulated Data

Manufacturer Heyer Products Company, Incorporated
Model Number . . . 168
Speed range 0-2500 rpm

Speed control Mechanical
Drive motor
Manufacturer Westinghouse Corporation
Style316 P558-A
Current requirement115-volt 60 cycle single phase
Vacuum pump assembly
Motor115-volt 60 cycle single phase
Pump2 cylinder
Weight and dimensions
Oversea pack 165 lbs
Unpacked109 lbs
Cube9.8 cu ft
Width20-1/8 inches
Height16 inches
Depth (front to rear)22-1/4 inches

TESTER, ENGINE DISTRIBUTOR	
Specification No.	MIL-T-13089A
Mfr's Model No.	168
Mfr's Serial No.	
Order No.	
Stock No.	4910-392-2939
HEYER PRODUCTS COMPANY INCORPORATED Belleville 9, New Jersey	

ORD F6120

Figure 2. Data plate.

CHAPTER 2

OPERATING INSTRUCTIONS

Section I. SERVICE UPON RECEIPT OF MATERIEL

8. Purpose

a. When a new or reconditioned tester is first received, it is the responsibility of the officer in charge to determine whether the materiel has been properly prepared for service by the supplying organization and to be sure it is in condition to perform its function. For this purpose, inspect all assemblies and parts to be sure they are properly assembled, secured, cleaned, adjusted, and/or lubricated.

b. Make a record of any missing or damaged parts, tools, and/or equipment, and of any malfunction. Correct any deficiencies as quickly as possible.

9. Services

a. *Unpacking and Checking.* Remove the top and all four sides from the base of the box. Remove the barrier material to expose the two rear hold-down bolts. Open the cover of the case, slide the cover to the left off the hinge pins, and remove the tools and equipment from the stowage compartment. Remove the two nuts from the bolts located in the bottom of the stowage compartment, and the two nuts from the bolts in the angle iron hold-down bar at the rear of the case. Lift the distributor tester off the four hold-down bolts, tip the tester forward and remove the two No. 10 x 3/4 pan-head thread forming tapping screws from the hold-down bar. Remove the hold-down bar and replace the screws in the bottom of the case. Unpack all tools and equipment and check against the tools and equipment listed in appendix II.

Note. When unpacking, check all wrappings closely to be sure that no tools or pieces of equipment are discarded with the packing material.

b. *Cleaning.* Clean the distributor tester and all tools and equipment as prescribed in paragraph 44.

c. *Installation.* Fabricate two hook bolts as shown in figure 3. Position the distribu-

tor tester on tie bench top and drill two 21/64-inch holes through the bench using the mounting holes in the bottom of the stowage compartment to determine the location of the holes. Locate and drill a 21/64-inch hole through the bench top, below the rear curve in each carrying handle and adjacent to the side of the case. Secure the front of the distributor tester to the bench with two 5/16-18 x 2 cap screws, two 5/16-inch flat washers, two 5/16-inch split lock washers, and two 5/16-18 hexagon plain nuts. Start the fabricated hook bolts through the bench top and, with the hook ends away from the case, force the hook bolts down to engage the carrying handles. Install a 5/16-inch flat washer, 5/16-inch split lock washer, and 5/16-18 hexagon plain nut on each hook bolt and tighten.

d. *Lubrication.* Lubricate the distributor tester as prescribed in paragraph 54 and lubrication chart (fig. 13).

e. *Inspection.*

Note. The key numbers shown below in parentheses refer to figure 4.

- (1) Turn the dwell meter adjustment screw (21) and the tachometer indicator adjustment screw (17) clockwise and counterclockwise to be sure they control the pointers and that the pointers are not binding. Set both pointers on zero. Set the dial on the vacuum gage (10) so that the zero is aligned with the pointer by turning the vacuum gage adjusting knob (11). Turn the power switch (3B) and the vacuum pump switch (12) off.
- (2) Connect the power cable (3A) to a 115-volt 60-cycle single-phase source. Turn the direction control switch (15) to the left hand rotation. Turn the speed range selector switch (16) to 0-2500. Turn the

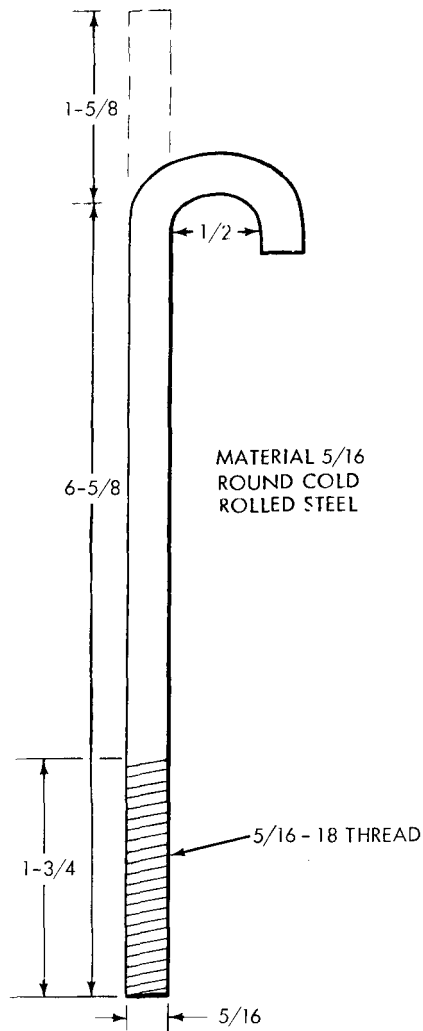

NOTE: ALL DIMENSIONS ARE IN INCHES

ORD F6121

Figure 3. Fabricated hook bolt.

power switch on and reduce the speed of the stroboscope drive shaft (23) to its lowest speed by turning the speed control (14) clockwise as far as possible.

Slowly increase the speed by turning the speed control counterclockwise. Listen for unusual noises and watch tachometer indicator to see if the speed increases at a steady rate as the speed control is turned. Reduce the speed to its minimum and turn the direction control switch to the off position until the drive motor stops. Turn the direction control switch to right hand rotation and perform the same checks as for left hand rotation. Turn the direction control switch to the off position. Perform the above checks at 0 to 500 rpm with the speed range selector switch in the 0-500 position.

- (3) Turn the vacuum pump switch (12) on and plug the end of the vacuum hose (9) by placing a finger over the hole. Decrease the vacuum to approximately 1 inch of mercury on the vacuum gage (10) by turning the vacuum pump control (13) counterclockwise. Then turn the control clockwise slowly and watch the pointer on the vacuum gage. The pointer should make approximately 1-1/2 revolutions and indicate a maximum reading of about 23 inches of mercury. See paragraph 24, for instructions on how to read the vacuum gage.
- (4) Remove the finger plugging the vacuum hose, turn off the vacuum switch, direction control switch, and power switch. Disconnect the power cable from the power source.

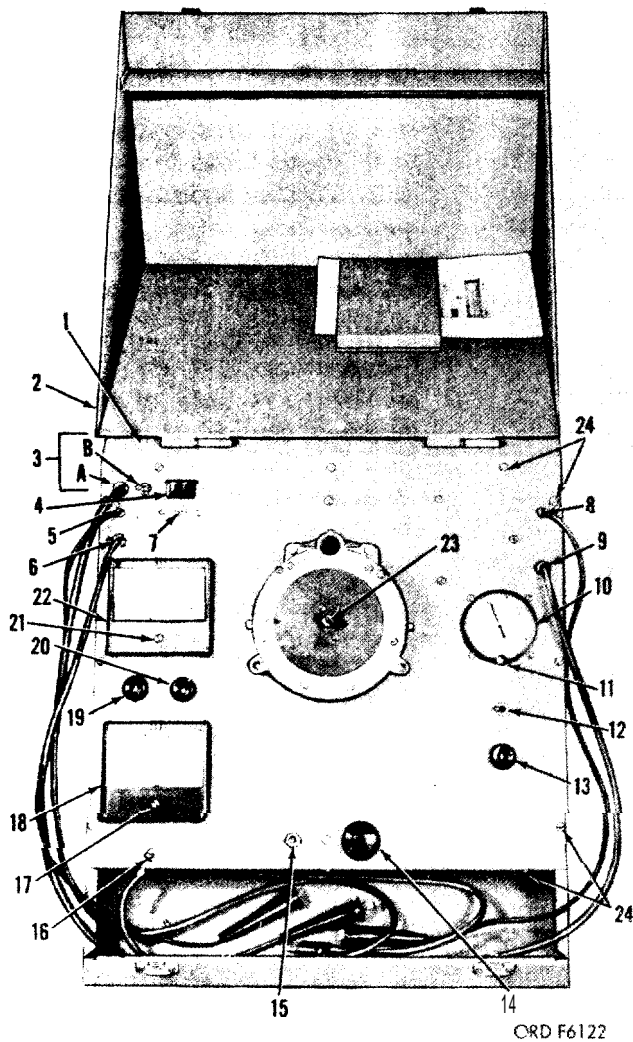

- 1-Case
 2-Hinged cover
 3-Power cable and power switch
 A-Power cable
 B-Power switch
 4-1 15-Volt electrical receptacle
 5-Coil I lead (no. 1)
 6-Cam angle lead
 7-Motor reset button
 8-Coil lead (no. 2)
 9-Vacuum hose
 10-Vacuum gage
 11-Vacuum gage adjusting knob
 12-Vacuum pump switch
 13-Vacuum pump control
 14-Speed control
 15-Direction control switch
 16-Speed range selector switch
 17-Tachometer indicator adjustment screw
 18-Tachometer indicator
 19-Cam angle adjustment
 20-Meter selector
 21-I-Dwell meter adjustment screw
 22-Dwell meter
 23-Stroboscope drive shaft
 24-No. 10 x 1/2 thread cutting tapping screw

Figure 4. Controls and instruments.

Section II. CONTROLS AND INSTRUMENTS

Note. The key numbers shown below in parentheses refer to figure 4.

10. General

This section describes, locates, and illustrates the various controls and instruments and furnishes the operator with sufficient information for the proper operation of the distributor tester.

11. Power Cable and Power Switch

The cable (3A) and switch (3B) (identified as "A, C. LEAD & SWITCH, OFF-ON") are located in the upper left hand corner of the instrument panel.

12. 115-Volt Electrical Receptacle

This receptacle (4) (Identified as "LAMP SOCKET") is located to the right of the power switch (3 B), and indicates that the receptacle is the power source for the work lamp.

13. Coil Leads

Coil No. 1 lead (5) (identified as "COIL #1 LEAD") is located just below the power cable; Coil No. 2 lead (8) (identified as "COIL #2 LEAD") is located on the right side of the instrument panel directly opposite the Coil No. 1 lead.

14. Motor Reset Button

The motor reset button (7) (identified as "MOTOR RESET") is located to the right of the Coil No. 1 lead and directly below the 115-volt electrical receptacle. The reset button is used to reset the switch provided as over-load protection for the drive motor.

15. Cam Angle Lead

The cam angle lead (6) is located directly below the Coil No. 1 lead (5) and is used to connect the distributor primary circuit to the dwell meter.

16. Dwell Meter

The dwell meter (22) (identified as "CAM DWELL" on the dial face) is located to the

left of the stroboscope and is calibrated in degrees from 0 to 50, with each individual marking indicating one degree of cam angle.

17. Cam Angle Adjustment

The cam angle adjustment (19) (identified as "ADJUST CAM ANGLE") is located on the left side of the instrument panel between the dwell meter and the tachometer indicator and is used in conjunction with the meter selector to align the pointer of the dwell meter (22) with the "ADJUST TO" reference line on the meter scale.

18. Meter Selector

The meter selector (20) is located to the right of the cam angle adjustment and between the dwell meter and the tachometer indicator. It is used to select the cam angle required for testing 4, 6, or 8 lobe distributors, and in conjunction with the cam angle adjustment (19), to align the dwell meter pointer, (16 above).

19. Tachometer Indicator

The tachometer indicator (18) (identified as "R.P.M." on the dial face) is located on the left side of the instrument panel directly below the cam angle adjustment (19) and the meter selector (20). It is actuated by a small built-in precision generator and is calibrated to indicate distributor shaft revolutions per minute. It has two scale ranges: 0 to 500 and 0 to 2500 rpm.

20. Speed Range Selector Switch

The speed range selector switch (16) (identified as "DISTRIBUTOR R.P.M.") is the two position toggle switch located directly below the tachometer indicator (18). It is used to select the desired range on the tachometer indicator; to the left for 0 to 500 rpm and to the right for 0 to 2500 rpm.

21. Direction Control Switch

The direction control switch (15) (identified as "DIRECTION CONTROL") is located on the lower part of the instrument panel to the left of center. This is a three position toggle switch. The toggle is pushed to the left for left hand rotation, to center for off, and to the right for right hand rotation. A caution against reversing the rotation without stopping the motor is printed directly above the switch.

22. Speed Control

The speed control (14) is located on the lower part of the instrument panel to the right of center. The control is turned clockwise to decrease the speed of the distributor shaft, and counterclockwise to increase the speed. A warning against turning the control without the motor running is printed directly above the control.

Note. The speed control should always be turned fully clockwise when the tester is not in use.

23. Vacuum Hose

The vacuum hose (9) is located on the right side of the instrument panel directly below the coil No. 2 lead (8).

24. Vacuum Gage

The vacuum gage (10) (identified as

"INCHES MERCURY" on the dial face) is located below and to the left of the vacuum hose (9). This gage shows the vacuum applied to the distributor diaphragm and is calibrated in inches of mercury. The scale is arranged so that the gage indicates from 0 to 10 inches of mercury on the first revolution of the pointer and from 10 to 24 inches of mercury on the second revolution. The first revolution is read on the outer scale and the second revolution is read on the inner scale. An adjusting knob is provided for aligning the zero on the dial with the pointer before starting the vacuum pump.

25. Vacuum Pump Switch

The vacuum pump switch (12) (identified as "OFF-ON") is the two position toggle switch located directly below the vacuum gage (10).

26. Vacuum Pump Control

The vacuum pump control (13) is located directly below the vacuum pump switch (12). The control is turned clockwise to increase the vacuum applied to the distributor diaphragm and counterclockwise to decrease the vacuum.

Note. The v pump control must never be turned counterclockwise further than required to set the vacuum at .01 inches of mercury since to do so will unscrew the valve stem from its housing.

Section III. OPERATION

27. General

This section contains instructions for the operation of the distributor tester under all conditions of temperature and humidity. Every organization equipped with this item must thoroughly train its personnel in the procedures for operating this item.

28. Preparation for Operation

Note. The key numbers shown below in parentheses refer to figure 5 unless otherwise indicated.

a. Install the drive column (4) in the stroboscope base casting (1) making sure it reaches the bottom of the hole. Place

the rubber drive coupling (7) on the stroboscope drive shaft. Place the universal distributor clamp (2) on the drive column and lower it so that the clamp jaws can engage the rubber drive coupling. Tighten the clamp locking knob (6) just enough to engage the rubber drive coupling without distorting it. Grasp the drive column and rotate it slightly in both directions and then half way back. This will center the clamp in relation to the drive column. Tighten the height adjustment knob (3) and secure the drive column in the stroboscope base casting with the two hexagon socket setscrews (9).

b. Slip the holder rod of the work lamp

(5) in the hole in the drive column and connect the plug in the electrical receptacle (4, fig. 4).

c. Turn the power switch (3B, fig. 4) and

the vacuum pump switch (12, fig. 4) off and connect the power cable (3A, fig. 4) to a 115-volt 60-cycle single-phase power source.

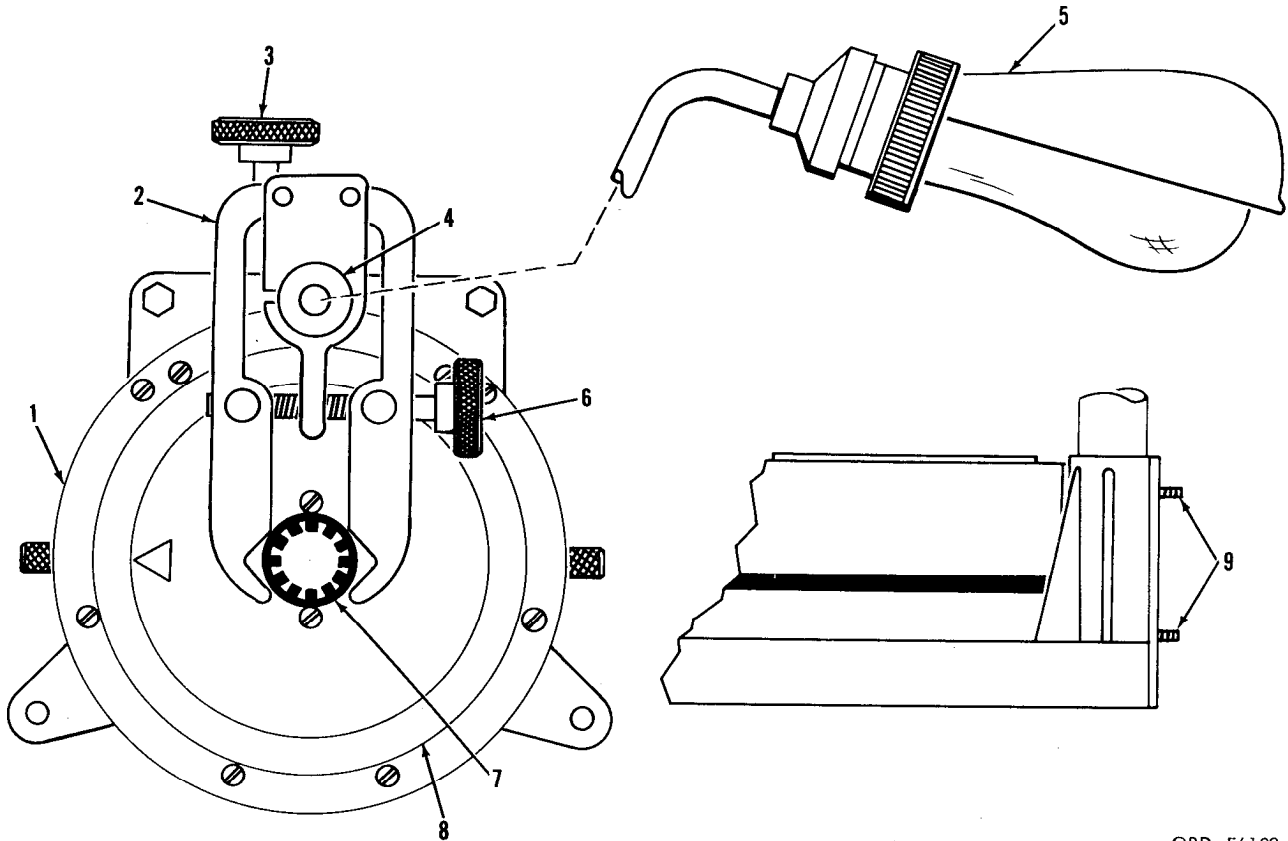

- 1—Stroboscope base casting
- 2—Universal distributor clamp
- 3—Height adjustment knob
- 4—Drive column
- 5—Work lamp

- 6—Clamp locking knob
- 7—Rubber drive coupling
- 8—Protractor disk
- 9—1/4-20 x 5/16 Hexagon socket setscrew

ORD F6123

Figure 5. Mounting stroboscope drive.

29. Operation

a. *General.* The seals on waterproof or sealed distributors are not to be broken prior to testing. An adapter (fig. 16) is furnished for testing distributors of this type. A spring resiliency tester (fig. 16) is furnished to test the tension of the breaker arm springs,

Note. On those distributors not having sealed caps, test the springs prior to the operational tests described below. On those distributors with sealed caps, test the springs after the preliminary tests have been made.

b. *General Mounting Instructions.* For

the majority of gear driven distributors, it is quicker and easier to mount the distributor by the use of the rubber drive coupling as shown in figure 6. However, for distributors not adaptable to the rubber drive coupling, a universal distributor drive chuck (fig. 7) is provided. Place the universal distributor drive chuck on the stroboscope drive shaft (23, fig. 4) and set the jaws vertical to the drive column in the position shown in the inset in figure 7. Insert the shaft of the distributor to be tested in the distributor clamp and tighten the

clamp knob. Lower the shaft of the distributor into the rubber jaws of the universal distributor drive chuck and secure the chuck. The chuck jaws should not be tightened until *after* the distributor is clamped in the universal distributor clamp (2, fig. 5) and the height adjustment knob (3, fig. 5) tightened. If vibration is noted during operation it may be eliminated by loosening the height adjustment knob and, with the distributor tester speeded up, move the distributor to the right or left as required for smoothest operation.

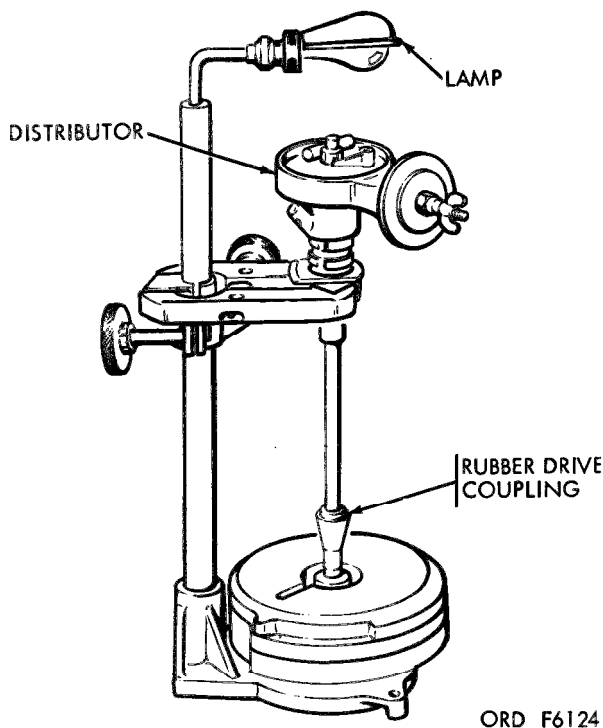

Figure 6. Rubber drive coupling mounting.

c. Mounting Governor Controlled Distributors (fig. 6) (with or without Vacuum Controlled Breaker Plate). Clamp the machined section of the distributor housing in the universal distributor clamp as shown in figure 6, press down slightly so the distributor gear will engage the rubber drive coupling firmly, and tighten the height adjustment knob. See paragraph *b* above for general mounting instructions. If the distributor has a vacuum control, install the correct adapter from the vacuum adapter kit (fig. 16) in the vacuum control and connect the vacuum hose (9, fig. 4) to the adapter.

d. Mounting Vacuum Controlled Distributors. Secure the universal distributor clamp (2, fig. 5) near the top of the drive column (4, fig. 5). Clamp the distributor shaft collet (fig. 16) in the universal distributor clamp with the knurled nut up. Remove the knurled nut and insert the correct bushing (fig. 16) into the collet with the flange up. Insert the distributor shaft through the bushing and secure the vacuum control mounting bracket to the stud on the collet with the knurled nut as shown in figure 8. Secure the distributor and collet with the clamp locking knob. Loosen the height adjustment knob (fig. 8), slide the distributor down on the drive column until the distributor gear or shaft engages the rubber drive coupling (7, fig. 5), or universal distributor drive chuck (fig. 7) and tighten the height adjustment knob. If the chuck is used, tighten the chuck jaws using the chuck wrench (fig. 16) after the alignment is made and the height adjustment knob is secured. Install the correct adapter from the vacuum adapter kit (fig. 16) in the vacuum control and connect the vacuum hose to the adapter. Mounting of distributors with the vacuum control attached directly to the distributor is accomplished the same as mounting distributors with no vacuum control. See paragraph *b* above for general mounting instructions.

e. Controls. Instructions for connecting, starting, operating, and stopping the distributor tester are contained in paragraph 9e.

30. Cam Angle Test

Note. The key numbers shown below in parentheses refer to figure 4.

a. Mount the distributor (par. 29). Zero the dwell meter (22), tachometer indicator (18), and vacuum gage (10) as prescribed in paragraph 9e(1). Put the direction control switch in the off position and turn the power switch (3B) on.

b. Set the meter selector (20) to the "ADJ & 8 CYL" position and connect the cam angle lead (6) to the distributor as shown in figure 9. If there is no reading on the dwell meter (22), rotate the distributor shaft until the distributor points

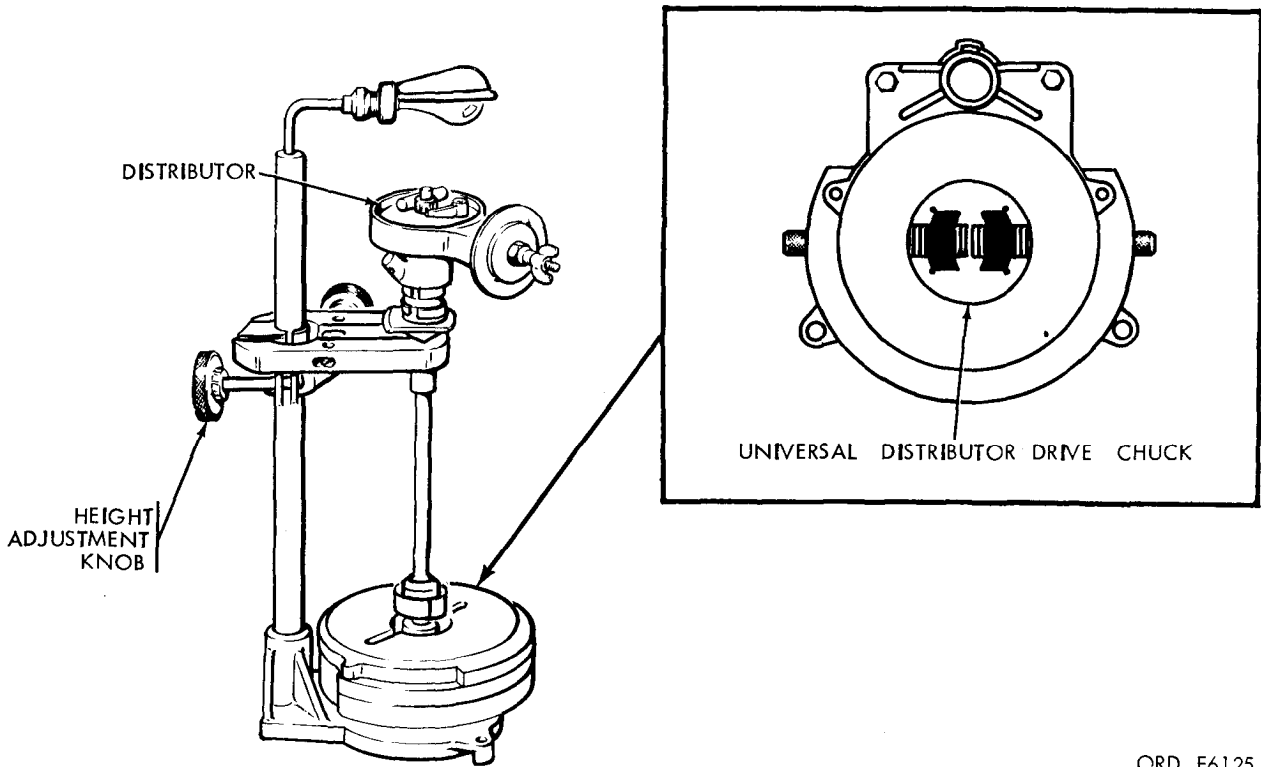

ORD F6125

Figure 7. Universal drive chuck mounting.

are closed and the dwell meter shows a reading. Align the meter pointer with the "adjust to line" mark on the meter scale using the cam angle adjustment (19).

c. Turn the meter selector to either the "4 CYL", "6 CYL", or "8 CYL" position, whichever corresponds with the number of lobes on the distributor cam.

d. Set the direction control switch (15), to the direction in which the distributor shaft is driven on the vehicle, and turn the speed range selector switch (16) to the 0-500 range.

e. Adjust the speed control (14) to the 200 rpm on the tachometer indicator (18) and read the cam angle degrees on the dwell meter and check this reading against the cam angle of the distributor as specified by the applicable TM or by the manufacturer of the distributor.

f. Turn the speed range selector to 0-2500 rpm and increase the speed to 2000 rpm. The reading on the dwell meter should be within 2 degrees of that obtained in e above.

g. Figure 9 shows the various types of

hook-up for distributors with vacuum controls, single condenser, two condensers

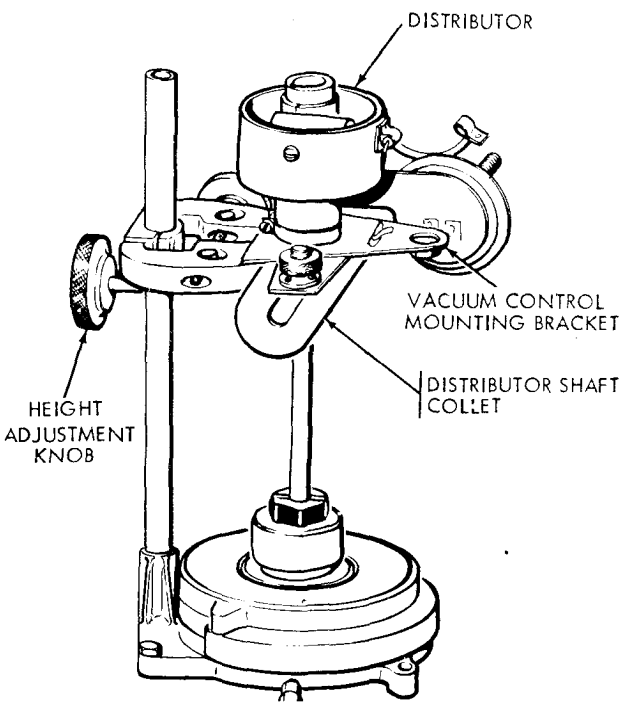

Figure 8. Mounting vacuum controlled distributor.

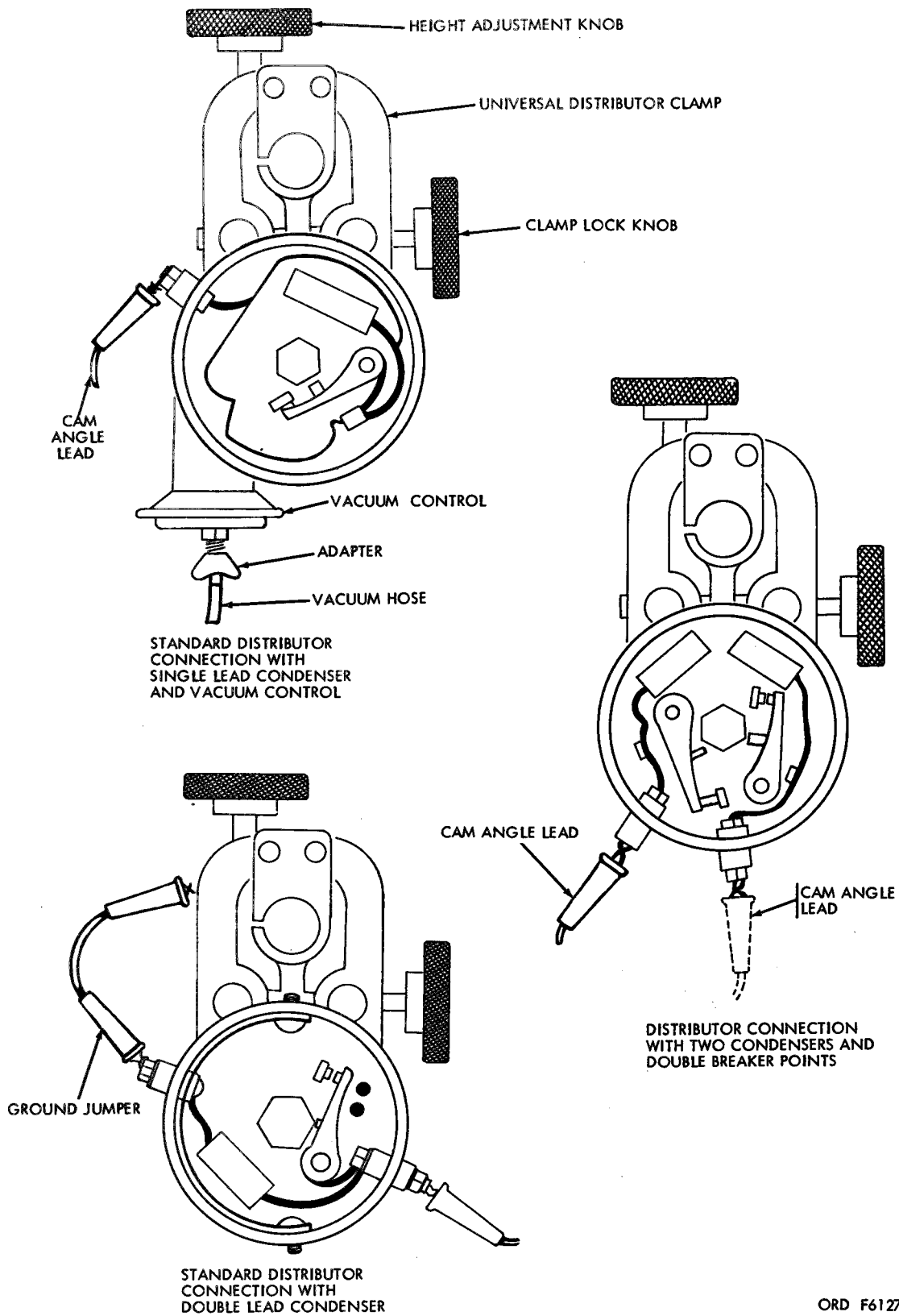

Figure 9. Cam angle test connections.

with double breaker points, and distributors with double lead condensers. On distributors with double breaker points the cam angle on each set of points are checked separately and each must show the same reading on the dwell meter. To block one set of breaker points open while testing the other set, place a piece of fiber or any nonconducting material between the points.

h. Turn the speed control (14) clockwise and reduce the speed to its lowest point on the 0-2500 range, switch the speed range selector to 0-500 range and adjust the distributor speed to 200 rpm. Disconnect the cam angle lead from the distributor and perform cam lobe test paragraph 31, 32, or 33 as applicable.

31. Cam Lobe Test for Single Coil Ignition Systems

a. Connect coil No. 1 lead (5, fig. 4) to the distributor terminal. Observe cam pattern of the stroboscope at 200 rpm. Adjust the protractor disk with the protractor setting knob so a flashing cam lobe aligns with the 4 - 6 - 8 mark as shown in figure 10.

b. Check the pattern on both speed ranges from 200 to 2000 rpm. Image pattern should remain steady. "Dancing" or misalignment of lines at high speed only, indicates bouncing of points, poor contact, weak springs, or friction in breaker arm bearing.

c. Turn the speed control fully clockwise, set the direction control switch in the off position, remove the coil lead, and snap the power switch off.

32. Cam Lobe Tests for Fly-ball Governor Spark Advance

a. Connect the coil No. 1 lead (5, fig. 4) to the distributor terminal. Aline the 4-6-8 mark on the protractor disk to coincide with one of the arrow flashes as shown in figure 11.

b. Adjust rpm as indicated inapplicable TM or manufacturer's specifications and observe the arrow flashes opposite the tester protractor disk to determine the degree of spark advance. The arrow flashes should conform to the spark ad-

vance (distributor degrees) specified, degree of spark advance. The arrow flashes should conform to the spark advance (distributor degrees) specified.

c. Turn the speed control fully clockwise, set the directional control switch in the off position, remove the coil lead, and snap the power switch off.

33. Cam Lobe Tests for Vacuum Controlled Spark Advance

a. Connect the coil No. 1 lead (5, fig. 4) to the distributor terminal. Adjust the speed of the distributor to the rpm called for in the applicable TM or manufacturer's specifications for the distributor. Then connect vacuum hose to distributor as described in paragraph 29c. Adjust vacuum as covered in specifications and check advance as shown in paragraph 32b above.

b. Turn the speed control fully clockwise, set the direction control switch in the off position, remove the coil lead and vacuum hose, and snap the power switch off.

34. Synchronizing Points on Double Coil, Double Breaker Arm, and Vertical Type Distributors

a. Double coil, double breaker distributors of the type shown in figure 12 require the use of two ignition coils in order to synchronize points and check their cam lobe accuracy. Connect coil No. 1 lead and coil No. 2 lead (5, and 8, fig. 4) to the two distributor terminals.

b. Set the stroboscope protractor ring for the proper distributor specification setting.

c. Turn the direction control switch to the direction in which the distributor shaft is driven in the vehicle and observe pattern of disk. Turn the power switch on and the speed control setting to 200 rpm.

d. Turn the synchronizing screw on the breaker arm plate (fig. 12) and, ignoring one set of flashes, adjust the flashes until the best match to all lines are achieved. If there is still more than 1 degree jog in any line, the cam is inaccurate.

Note. Be sure to lock breaker in position after completing adjustment.

PERFECT 8 LOBE CAM PATTERN

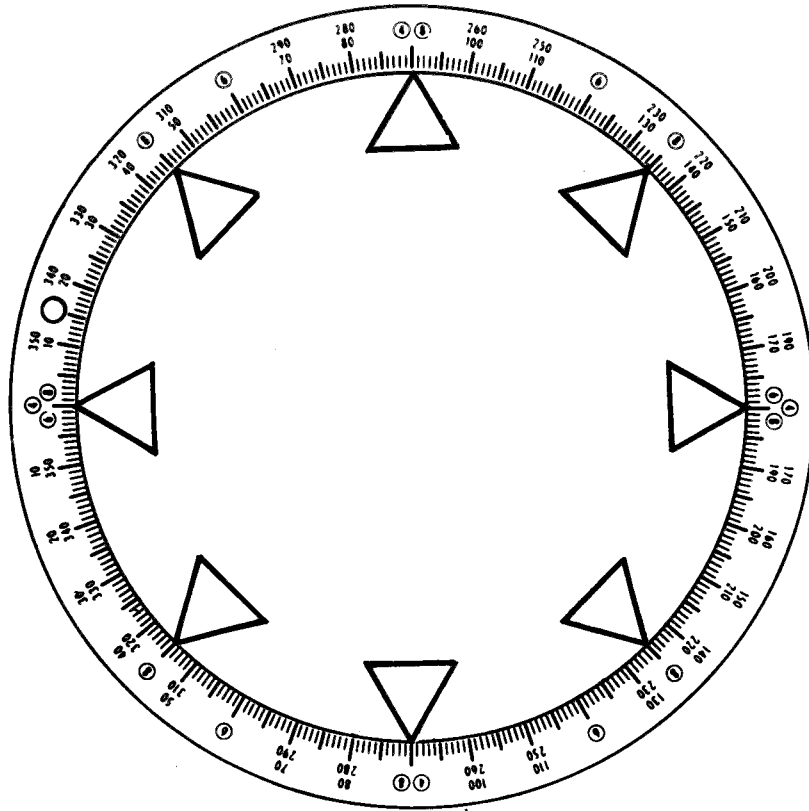

IMPERFECT 8 LOBE CAM PATTERN

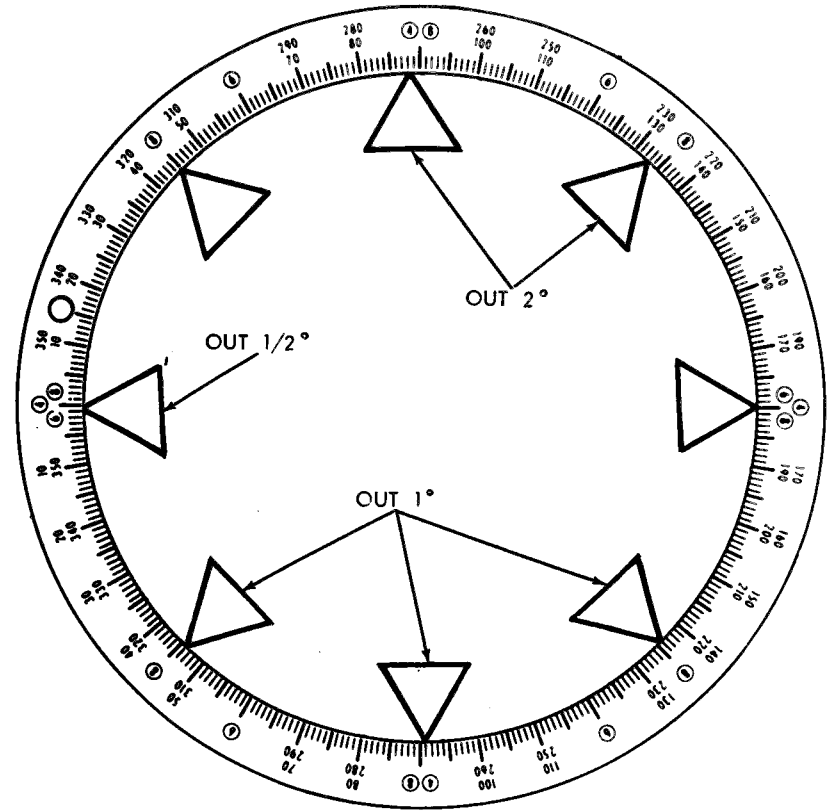

ORD F6128

Figure 10. Setting cam lobe.

e. Adjust the distributor speed to 2000 rpm. If lines now dance and shift, this indicates bouncing points at high speed due to weak breaker arm springs or friction in breaker arm bearings.

f. Turn the speed control fully clockwise, set the direction control switch in the off position, remove the coil leads, and snap the power switch off.

35. Shutting Down Tester After Use

a. Check to see that the speed control (14, fig. 4) and cam angle adjustment (19,

fig. 4) are turned counterclockwise to their lowest points.

b. Check to see that the vacuum pump switch (12, fig. 4), direction control switch (15, fig. 4) and power switch (3B, fig. 4) are in their off position.

c. Disconnect the power cable (3A, fig. 4) from the power source and the work lamp lead from the 115-volt electrical receptacle.

d. Wrap the power cable, leads, and vacuum hose and stow them in the stowage compartment.

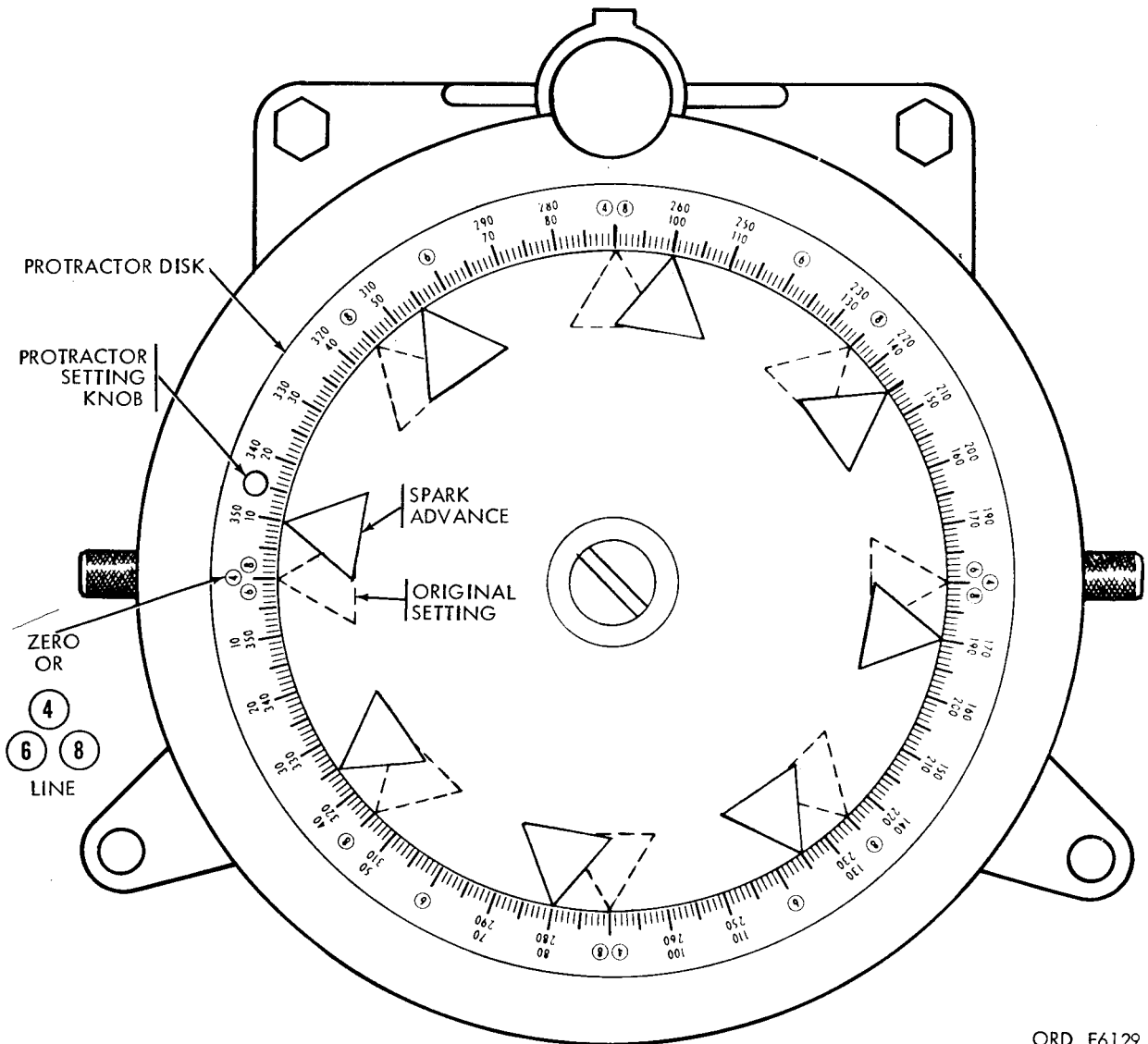

ORD F6129

Figure 11. Spark advance as shown on stroboscope.

e. Remove the universal distributor clamp (2, fig. 5) and drive column (4, fig. 5) from the stroboscope base casting. Stow the items in the stowage compartment.

f. Stow the tools and equipment in the stowage compartment, close and latch the cover.

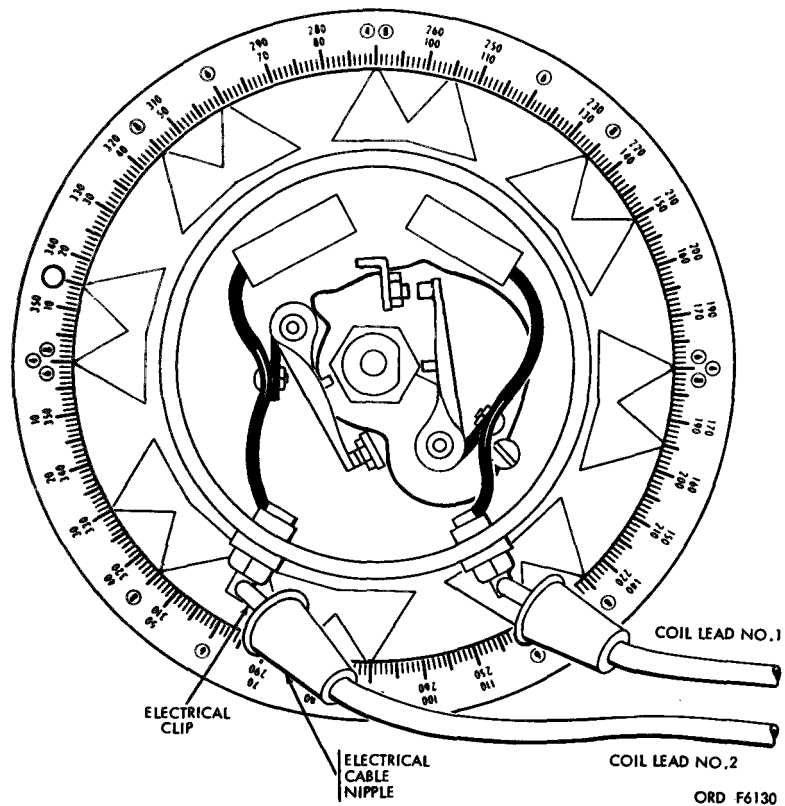

Figure 12. Synchronizing points on double coil, double point type distributors.

CHAPTER 3

OPERATOR MAINTENANCE INSTRUCTIONS

Section I. REPAIR PARTS, TOOLS, AND EQUIPMENT

36. General

Repair parts, tool, and equipment are issued to the operator for operating and maintaining the tester. Tools and equipment should not be used for purposes other than prescribed and when not in use, should be properly stowed.

37. Repair Parts

No repair parts are supplied to the operator for replacement on the tester.

38. Common Tools and Equipment

Common tools and equipment having general application to this materiel are authorized by tables of allowances and tables of organization and equipment.

39. Special Tools and Equipment

Certain tools and equipment specially designed for operation and operator maintenance, repair, and general use with the materiel are listed in appendix II, which is the authority for requisitioning replacements.

Section II. PREVENTIVE-MAINTENANCE SERVICES

40. General

Preventive maintenance is the systematic care, inspection, and servicing of equipment to maintain it in a serviceable condition, prevent break-downs, and assure maximum operational readiness. First echelon preventive maintenance is accomplished by the equipment operator. The operator's role in the performance of preventive-maintenance service is:

a. To perform the daily service each day the equipment is operated.

b. To assist the organizational maintenance mechanics in the performance of any other scheduled periodic services specified by pertinent technical manuals.

c. To assist the organizational maintenance mechanics in the lubrication of the equipment in accordance with the pertinent lubrication order.

41. Responsibility

Operators and crew chiefs are personally responsible for assigned equipment. Squad, section, and platoon leaders are charged with supervisory responsibility

for equipment pertaining to their commands. Unit and organization commanders are required to insure that equipment issued or assigned to their commands are properly maintained in a serviceable condition, and that they are properly cared for and used.

42. Recording Repairs

Repairs accomplished will be in accordance with procedures and standards prescribed in appropriate technical manuals. The equipment record system provides for recording repairs required and accomplished on specific items of equipment. This will include, but is not limited to, adjusting, cleaning, and replacing unserviceable parts. Deficiencies discovered before, during, and after operation that cannot be corrected by the operator will be entered on DA Form 2404. Deficiencies immediately corrected by the operator are not recorded, except when such corrections are made by replacing parts or which constitute repairs above first echelons. Such repairs will be recorded as organizational maintenance.

43. General Procedures for All Services and Inspections

a. The following general procedures apply to first-echelon preventive-maintenance services and all inspections, and are just as important as the specific procedures.

b. Inspection to see if items are in good condition, correctly assembled or stowed, secure, not excessively worn, not leaking, and adequately lubricated apply to most items in the preventive-maintenance and inspection procedures. Any or all of these checks that are pertinent to any item (including supporting, attaching, or connecting members) will be performed automatically, as general procedures, in addition to any specific procedures given.

- (1) Inspection for "good condition" is usually an external visual inspection to determine whether the unit is damaged beyond safe or serviceable limits. Good condition is explained further as meaning: not bent or twisted, not chafed or burred, not broken or cracked, not bare or frayed, not dented or collapsed, not torn or cut, not deteriorated.
- (2) Inspection of a unit to see that it is correctly assembled or stowed is usually a visual inspection to see if the unit is in its normal position in the vehicle, and if all its parts are present and in their correct relative position.
- (3) Inspection of a unit to determine if it is "secure" is usually an external visual examination or a check by hand, wrench, or pry-bar for looseness. Such an inspection must include any brackets, lockwashers, locknuts, locking wires, or cotter pins as well as any connecting tubes, hoses, or wires.
- (4) By "excessively worn" is meant worn beyond serviceable limits or to a point likely to result in failure if the unit is not replaced before the next scheduled inspection. Excessive wear of mating parts or linkage connection is usually evidenced by too much play (lash or

lost motion). It includes illegibility as applied to markings, data and caution plates, and printed matter.

- (5) Where the instruction "tighten" appears in the procedure, it means tighten with a wrench, even if the item appears to be secure.
- (6) Such expressions as "adjust if necessary" or "replace if necessary" are not used in the specific procedures. *It is understood that whenever inspection reveals the need of adjustment, repairs, or replacement, the necessary action will be taken.*

44. Cleaning

a. *General.* Any special cleaning instructions required for specific components or parts are contained in the pertinent section. General cleaning instructions are as outlined in (1) through (3) below.

- (1) *Metal parts.*
 - (a) Use self-emulsifying decreasing solvent compound, mineral spirits paint thinner, or dry-cleaning solvent (Stoddard) to clean or wash grease or oil from all metal parts of the tester.
 - (b) Use clean water or a solution of either 1/4 pound of soap chips or 6 ounces of painted-surface detergent to 1 gallon of hot water for all parts and overall general cleaning of painted surfaces.
 - (c) After parts are clean, dry them thoroughly. Apply a light film of special preservative lubricating oil to all parts having a polished surface to prevent misting.
 - (d) Before installing new parts, remove any rust-preventive compound, protective grease, etc.; prepare as required (oil seals, etc.); and for those parts requiring lubrication, apply the lubricant prescribed in the lubrication chart.
- (2) *Electrical parts.* Use trichloroethane for cleaning electrical parts. Do not use on material soluble in trichloroethane.

Warning: Repeated contact of

trichloroethane with the skin or prolonged breathing of the fumes is dangerous. Make sure adequate ventilation is provided.

- (3) **Rubber parts other than electrical.** Clean rubber parts with soap and warm water and dry thoroughly.

b. General Precautions in Cleaning.

- (1) Provide adequate ventilation both during and after use of trichloroethane. Work rooms must not be closed in. Avoid prolonged inhalation of vapor; headache or nausea may result. In contact with skin, this cleaner may cause irritation.
- (2) Self-emulsifying decreasing solvent compound, mineral spirits paint thinner, and dry-cleaning solvent are flammable and should not be used near an open flame. Fire extinguishers should be provided when these materials are used. Use only in well-ventilated places. These cleaners evaporate quickly and have a drying effect on the skin. If used without gloves, they may cause cracks in the skin and, in the case of some individuals, a mild irritation or inflammation.
- (3) Avoid getting petroleum products, such as mineral spirits paint thinner, dry-cleaning solvent, engine fuels, or lubricants, on rubber parts, as they will deteriorate the rubber.
- (4) The use of Diesel fuel oil, gasoline, or benzene (benzol) for cleaning is prohibited.

c. Rust Removal. Remove rust or corrosion from all parts of the materiel. To remove rust or corrosion from unfinished surfaces, use steel cleaning brushes or abrasive cloth. On finished surfaces, other than highly polished surfaces, remove rust or corrosion by buffing with a rotary wheel wire brush constructed of steel wire between 0.010 and 0.025 inch in diameter. Crocus cloth may be used manually to remove rust or corrosion from polished surfaces.

45. Preventive Maintenance by Operator

a. Purpose. To assure maximum operational readiness, it is necessary that the equipment be systematically inspected at intervals every day it is operated, so defects may be discovered and corrected before they result in serious damage or failure. Certain scheduled maintenance services will be performed at these designated intervals. Any deficiencies discovered that cannot be corrected by the operator, or corrected by replacing parts will be reported on DA Form 2404.

b. Daily Preventive-Maintenance Service. Each equipment will be inspected each day that it is operated. This service is divided into three parts, as indicated in (1) through (3) below.

- (1) **Before-operation service.** This is a brief service to ascertain that the equipment is ready for operation; it is mainly a check to see if conditions affecting the equipment's readiness have changed since the last after-operation service.
- (2) **During-operation service.** This service consists of detecting unsatisfactory performance.
- (3) **After-operation service.** This is the basic daily service for the equipment. It consists of correcting, insofar as possible, any operating deficiencies. Thus, the equipment is prepared to operate upon a moment's notice.

46. Specific Procedures for First Echelon

Table I gives the specific procedures to be performed on the equipment by the operator for each daily service.

Table I. Preventive-Maintenance Checks and Services

1st Echelon			Daily Schedule		
Interval and sequence			Item to be inspected	Procedure	Paragraph reference
Before operation	During operation	After operation			
1			Cables and leads.	Inspect each cable and lead for	-----

Table 1. Preventive-Maintenance Checks and Services-Continued

Interval and sequence			Item to be inspected	Procedure	Paragraph reference
Before operation	During operation	After operation			
			leads.	cable and lead for frayed insulation and other damage.	
2			Switches --	Snap switches and check for positive action. After check make sure all switches are in the off position.	Par. 9c and fig. 4.
3			Meters ---	Zero all meters	Par. 9e and fig. 4.

Interval and sequence			Item to be inspected	Procedure	Paragraph reference
Before operation	During operation	After operation			
	4		Unusual operational noises or vibration.	Loosen universal clamp jaws slightly and turn distributor back and forth to center drive shaft.	Par. 29b.
		5	Distributor tester.	Wipe all grease and dirt from the tester. Remove installed column and other equipment, store in its proper place and close and latch the cover.	Par. 35.

Section III. TROUBLESHOOTING

47. Purpose

Troubleshooting is a systematic determination of malfunctions and defective components by indications, symptoms, and tests. Close adherence to the procedures covered herein will materially reduce the time required to locate trouble and restore the materiel to normal operation.

Caution: Operation of materiel without a preliminary examination can cause further damage to a disabled component. Be careful during inspection and troubleshooting, so that damage can be avoided.

48. Scope

This section covers troubleshooting which is peculiar to the operator's (first echelon) maintenance operations.

49. Procedure

Malfunctions which may occur with the tester are listed in table II. Upon observing any one of these malfunctions, take immediate steps to locate and correct the cause. Causes are listed opposite each

malfunction and are arranged according to the ease of correction.

Table II. Troubleshooting

Malfunction	Probable cause	Corrective action
1. Distributor tester fails to start.	a. Power cable not connected.	a. Insert plug of power cable into power source receptacle so it makes good contact (par. 28c).
	b. Other causes --	b. Refer other causes to organizational maintenance personnel for correction.
2. Work lamp fails to light.	a. Lamp lead not connected.	a. Insert plug on lamp lead into 115 volt electrical receptacle (par. 28b).
	b. Other causes --	b. Refer other causes to organizational maintenance personnel for correction.

Table II. Troubleshooting-Continued

Malfunction	Probable cause	Corrective action
3. Tester chatters or vibrates under speed.	<p>Shaft of distributor off center.</p> <p>Rubber jaws on universal distributor drive chuck set before universal distributor clamp was tightened.</p> <p>Other causes --</p>	<p>a. Loosen universal distributor clamp and center distributor shaft (par. 29b).</p> <p>b. Loosen clamp, align distributor and tighten chuck drive jaws. Tighten clamp after jaws are set (par. 29b).</p> <p>c. Refer other causes to organizational maintenance personnel for correction.</p>
4. Vacuum pump fails to create	Vacuum hose not tight on adapter of	a. Secure vacuum hose tightly on adapter.

Malfunction	Probable cause	Corrective action
desired vacuum control to distributor	<p>vacuum control.</p> <p>1. Other causes --</p>	<p>b. Refer other causes to organizational maintenance personnel for correction.</p>
5. Speed meter, cam dwell meter, and vacuum meter do not register same when distributor is tested the second time.	<p>1. Meters not zeroed.</p> <p>2. Other causes --</p>	<p>a. Zero each meter prior to testing each time.</p> <p>b. Refer other causes to organizational maintenance personnel for correction.</p>

CHAPTER 4

ORGANIZATIONAL MAINTENANCE INSTRUCTIONS

Section I. REPAIR PARTS, TOOLS, AND EQUIPMENT

50. General

Repair parts, tools, and equipment over and above those available to the operator are supplied to the using organization for maintaining the tester. Tools and equipment should not be used for purposes other than prescribed and, when not in use, should be properly stored.

51. Repair Parts

Repair parts are supplied to the using organization for replacement of those parts most likely to become worn, broken, or otherwise unserviceable, providing replacement of these parts is

within the scope or organizational maintenance functions. Repair parts supplied for the tester are listed in appendix IV of this manual.

52. Common Tools and Equipment

Common tools and equipment having general application to this materiel are authorized by tables of allowances and tables of organization and equipment.

53. Special Tools and Equipment

No tools or equipment specially designed for organizational maintenance are supplied or required for the tester.

Section II. LUBRICATION AND PAINTING

54. Lubrication Chart

Since disassembly of the tester is required, all lubrication is to be performed by organizational maintenance personnel. The lubrication chart (fig. 13) prescribes cleaning and lubrication procedures as to location, interval, and proper materials for the tester.

a. General Disassembly and Assembly Instructions.

- (1) Remove the twelve No. 10 x 1/2 thread-cutting tipping screws (24, fig. 4) bolting the control panel in place and lift the tester out of the case (1, fig. 4).
- (2) Prop the tester on end so lubrication may be applied.
- (3) After lubrication has been performed, place the tester back in the case, line up the screw holes, and secure with the twelve screws.

b. Points of Application. Oilers and oil holes are shown in figure 14 and are keyed to facilitate referencing in the lubrication chart (fig. 13). Wipe these devices and the surrounding surfaces clean before applying lubricant.

c. Reports and Records.

- (1) Report unsatisfactory performance of prescribed lubricants and preserving materials, using DA Form 2407, Maintenance Request.
- (2) Maintain a record of the tester on DA Form 2408-2, Lubrication Record.

55. Painting

Instructions for preparation of materials for painting, methods of painting, and materials to be used are contained in TM 9-213. Materials for painting are listed in appendix IV of this manual.

LUBRICATION CHART

TESTER, ENGINE DISTRIBUTOR, BENCH-TYPE,
6, 12, AND **24-VOLT, SGL-PH**, 60 CYCLE, 115 VOLT
(HEYER PRODUCTS COMPANY INC.)
(MODEL 168) (4910-392-2939)

Intervals are based on normal operations. Reduce to **compensate** for abnormal operation and severe conditions or contaminated lubricants. During inactive periods, intervals may be extended **commensurate** with adequate preservation.

Clean oil points before lubricating. Clean parts with **THINNER**, paint, mineral spirits (TPM), or **SOLVENT**, dry-cleaning (**SD**). Dry before lubricating. Dotted arrow points indicate lubrication on both sides of the equipment.

LUBRICANT . INTERVAL

A, FIG. 1

3042
3 or 4 drops
(See note 1)

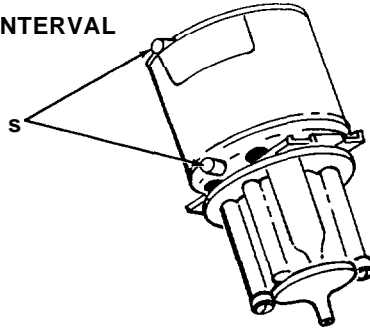

B, FIG. 1

3042
3 or 4 drops
(See note 1)

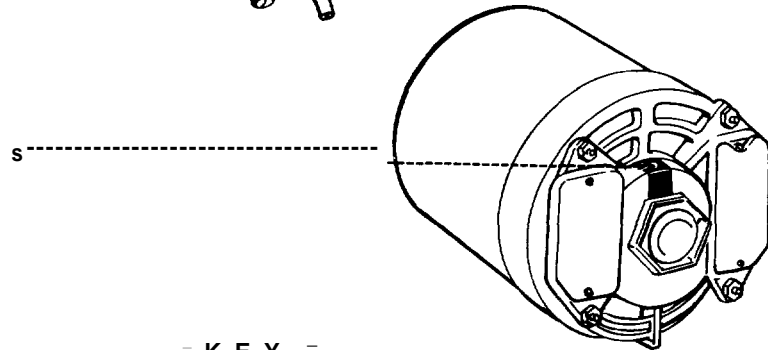

- KEY -

LUBRICANT	ALL TEMPERATURES	INTERVAL
3042 LUBRICATING OIL, general purpose	3042	s - Semi-annually

NOTES:

- VACUUM PUMP AND DRIVE MOTOR** — Remove tester from case, wipe oil points clean and insert 3 or 4 drops of lubricating oil.
- UNPAINTED FERROUS METAL SURFACES** — Wipe with an oiled cloth to preserve finish.

ORD F

Figure 13. Lubrication chart.

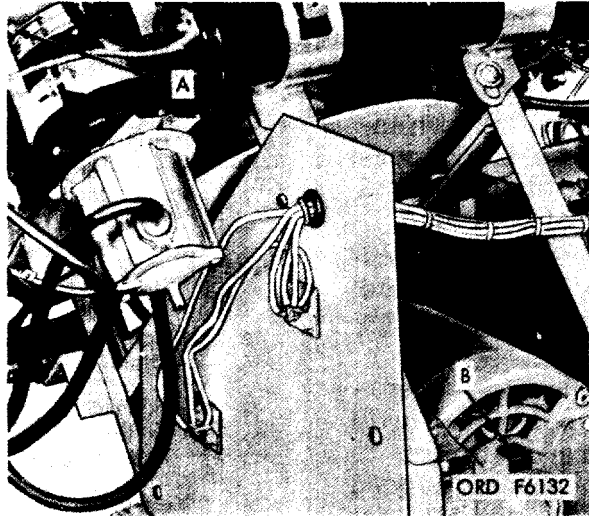

Figure 14. Points of application.

Section III. PREVENTIVE-MAINTENANCE SERVICES

56. General

Preventive maintenance is the systematic care, inspection, and servicing of equipment to maintain it in serviceable condition, prevent breakdown, and assure maximum operational readiness. Second echelon preventive maintenance is accomplished by the organizational mechanics. Their role in the performance of preventive-maintenance services is:

a. To perform the periodic services specified.

b. To lubricate the equipment in accordance with the lubrication chart (par. 54).

57. Recording Repairs

Repairs accomplished will be in accordance with procedures and standards prescribed in appropriate technical manuals. The equipment record system provides for recording repairs required and accomplished on specific items of equipment. This will include, but is not limited to, adjusting, cleaning, replacing, and straightening. Deficiencies and shortcomings not corrected by operators or crew, or those discovered during periodic inspections, will be corrected

insofar as possible by second-echelon maintenance personnel. These repairs will be indicated on DA Form 2404 and recorded on the organizational maintenance record of the equipment log.

58. General Procedures

a. *Automatically Applied.* All of the general procedures given in the operator's manual will be followed. Organizational mechanics must be so thoroughly trained in these procedures that they apply them automatically at all times in the performance of their duties.

b. *First-Echelon Participation.* The operator usually accompanies the equipment and assists the organizational mechanics in the performance of second-echelon periodic services.

c. *Plates.* Nameplates, caution plates, and instruction plates made of steel rust very rapidly. When they are found to be in a rusty condition, they should be thoroughly cleaned and heavily coated with an application of lacquer. Refer to TM 9-213.

d. *Services.* Second-echelon services are defined by, and restricted to the following general procedures unless

approval has been given by the supporting field organization.

- (1) *Adjust.* Make all necessary adjustments in accordance with instructions contained in the pertinent section of this technical manual or technical bulletin.
- (2) *Clean.* Clean the unit as outlined in paragraph 44 to remove old lubricant, dirt, and other foreign material.
- (3) *Tighten.* All tightening operations should be performed with sufficient wrench torque to tighten the unit according to good mechanical practice. Do not over-tighten, as this may strip threads or cause distortion. Tightening will always be understood to include the correct installation of lockwashers, lock nuts, locking wire, or cotter pins, to secure the tightened nut.

59. Specific Procedures for Second Echelon

Table III gives the specific procedures to be performed on the vehicle by second-echelon personnel for each monthly "M" service.

Table III. Preventive-Maintenance Checks and Services

2nd Echelon		Monthly Schedule	
Sequence number	Item to be inspected	Procedure	Paragraph reference
1	Work lamp.	Check for damaged or frayed wire. Replace unserviceable incandescent lamp.	Par. 66
2	Electrical clips.	Straighten bent electrical clips or replace.	Par. 64
3	Electrical cable nipples.	Replace cracked or damaged electrical cable nipples.	Par. 64
4	Vacuum pump.	Start tester vacuum pump, plug vacuum hose and check to see if vacuum reaches its maximum on vacuum gage. Adjust vacuum pump as required.	Par. 68d
5	Tester case and control panel.	Check for dents and exposed surfaces. Straighten dents, tighten loose screws, and paint exposed surfaces.	See par. 55 for painting instructions.

Section IV. TROUBLESHOOTING

60. Purpose

Troubleshooting is a systematic determination of malfunctions and defective components by indications, symptoms, and tests. Close adherence to the procedures covered herein will materially reduce the time required to locate trouble and restore the materiel to normal operation.

Caution: Operation of materiel without a preliminary examination can cause further damage to a disabled component. Be careful during inspection and troubleshooting, so that damage can be avoided.

61. Scope

This section covers troubleshooting which is peculiar to organizational (second echelon) maintenance operations.

For troubleshooting procedures by the operator, see section II, chapter 3.

62. Procedure

Malfunctions which may occur with the tester are listed in tables II and IV. In effect, table IV is a continuation of table II. Causes are listed opposite each malfunction and are arranged according to the ease of correction.

Table IV. Troubleshooting

Malfunction	Probable cause	Corrective action
1. Distributor tester fails to start.	a. Loose power cable.	a. Remove tester from case (par 68b) and see that wires are secure on power switch.

Table IV. Troubleshooting-Continued

Malfunction	Probable cause	Corrective action
	. Other causes --	b. Refer other causes to field maintenance personnel.
2. Work lamp fails to light.	Incandescent lamp burned out.	a. Replace incandescent lamp (par. 66d).
	. Other causes --	b. Refer other causes to field maintenance personnel.
3. Tester chatters or vibrates under speed.	. Motor bearings require lubrication.	a. Lubricate tester (par. 54).
	b. Other causes --	b. Refer other causes to field maintenance personnel.
4. Vacuum pump fails to create desired vacuum control to distributor.	t. Vacuum pump needs adjustment.	a. Adjust vacuum pump (par. 68d).
	b. Other causes --	b. Refer other causes to field maintenance personnel.
5. Speed meter, cam	-----	Refer malfunction to field

Malfunction	Probable cause	Corrective action
dwelling meter, and vacuum meter do not register same when distributor is tested the second time.		maintenance personnel for correction.
6. Electrical clips do not make positive connection.	a. Electrical clips bent from rough usage. b. Electrical clips burned from arcing. c. Electrical clips broken by rough usage.	a. Straighten electrical clips (par. 64d). 5. Clean electrical clips (par. 64c). c. Replace electrical clips (par. 64e).
7. Electrical cable nipples do not insulate electrical clips properly.	a. Electrical cable nipples crushed or cut. b. Electrical cable nipples deteriorated.	a. Replace electrical cable nipples (par. 64e). b. Replace electrical cable nipples (par. 64e).

Section V. ELECTRICAL CLIPS AND ELECTRICAL CABLE NIPPLES

63. Description

There are three electrical clips (fig. 12) on the tester, one on each of the two coil leads and one on the cam angle lead. The clips are alligator type and are attached to the leads with a single screw terminal. The electrical cable nipples (fig. 12) are insulators made of rubber or plastic, are 2-37/64 long overall, and completely cover the electrical clips. The nipples are easily slipped up the cable to allow access to the terminals on the electrical clips.

64. Maintenance

a. *General.* Organizational maintenance is limited to repair or removal, installation, and replacement of the electrical clips and replacement of the electrical cable nipples.

b. *Removal.* Slide the electrical cable nipples up the leads far enough to expose the entire electrical clips, loosen the

terminal screw and remove the electrical clips. Pull the electrical cable nipples off the leads.

c. *Cleaning and Inspection.*

(1) *Cleaning.* Using a stiff bristle brush remove the burns, rust, and corrosion from the electrical clips. Clean the electrical cable nipples as set forth in paragraph 44a(3).

(2) *Inspection.* Inspect the electrical clips for breaks, cracks, and distortion. Inspect the electrical cable nipples for cracks and deterioration.

d. *Repair.* Using pliers straighten bent electrical clips and align the serrated jaws so they will interlock.

e. *Installation.* Slide the electrical cable nipples, 5175-383-1318, over the leads and up far enough to expose the tip of the lead for attaching the electrical clips. Attach the electrical clips (5940-186-8928) to the cam angle lead and

5940-621-3276 to the coil leads) and secure the clips with the terminal screws. Slide the electrical cable nipples down

over the electrical clips until they are completely covered.

Section VI. WORK LAMP

65. Description

The work lamp (5, fig. 5) is an assembly consisting of a 3/8 inch brass tubing bent at 90 degrees on which a lamp socket is attached. A lamp lead with a two prong plug is attached to the assembly for plugging into a 115-volt electrical receptacle (4, fig. 4). The fifty watt incandescent lamp used for illumination is covered by a shield to protect the operators eyes from the glare and concentrate the light on the tester control panel. The work lamp is mounted by inserting the end of the bent tubing in the hole in the top of the drive column (4, fig. 5) and the plug of the lamp lead into the 115-volt electrical receptacle.

66. Maintenance

a. General. Organizational main-

tenance is limited to removal and inspection of the unit and replacement of the incandescent lamp.

b. Removal. Remove the plug from the 115-volt electrical receptacle and lift the work lamp from the drive column. Unscrew the incandescent lamp from the socket.

c. Inspection. Inspect the lamp lead for scuffed insulation and deterioration. Inspect the plug for bent prongs and other damage.

d. Installation. Install the incandescent lamp 6340-155-8634 in the lamp socket. Insert the rod of the work lamp into the hole in the top of the drive column and the plug in the 115-volt electrical receptacle.

Section VII. VACUUM PUMP

Note. The key numbers shown below in parentheses refer to figure 15 unless otherwise indicated.

67. Description

The vacuum pump mounted on the underside of the control panel directly under the vacuum gage (10, fig. 4) is a self contained unit consisting of a electric motor and a two cylinder piston type pump which is capable of vacuum equal to 24 inches of mercury. The function of the pump is to duplicate the manifold or venturi vacuum of the engine and is used for testing those distributors that operate on vacuum spark advance mechanism. A rubber hose is connected to each of the two cylinders of the pump which through a copper "Y" are connected to the vacuum pump control (13, fig. 4). The vacuum hose (9, fig. 4) and the hose to the vacuum gage are connected directly to the vacuum control.

68. Maintenance

a. General. Organizational maintenance is limited to removal of the tester from the case, its installation, and inspection and adjustment of the vacuum pump.

b. Removal. Remove the twelve No. 10 x 1/2 thread-cutting tapping screws (24, fig. 4) holding the control panel in place and lift the tester out of the case (1, fig. 4).

c. Inspection. Inspect the hoses and vacuum pump for good condition (par. 43b(1)).

d. Adjustment.

- (1) Turn the vacuum pump control (13, fig. 4) fully clockwise.
- (2) Prop the tester on end so the top of the pump is easily accessible.

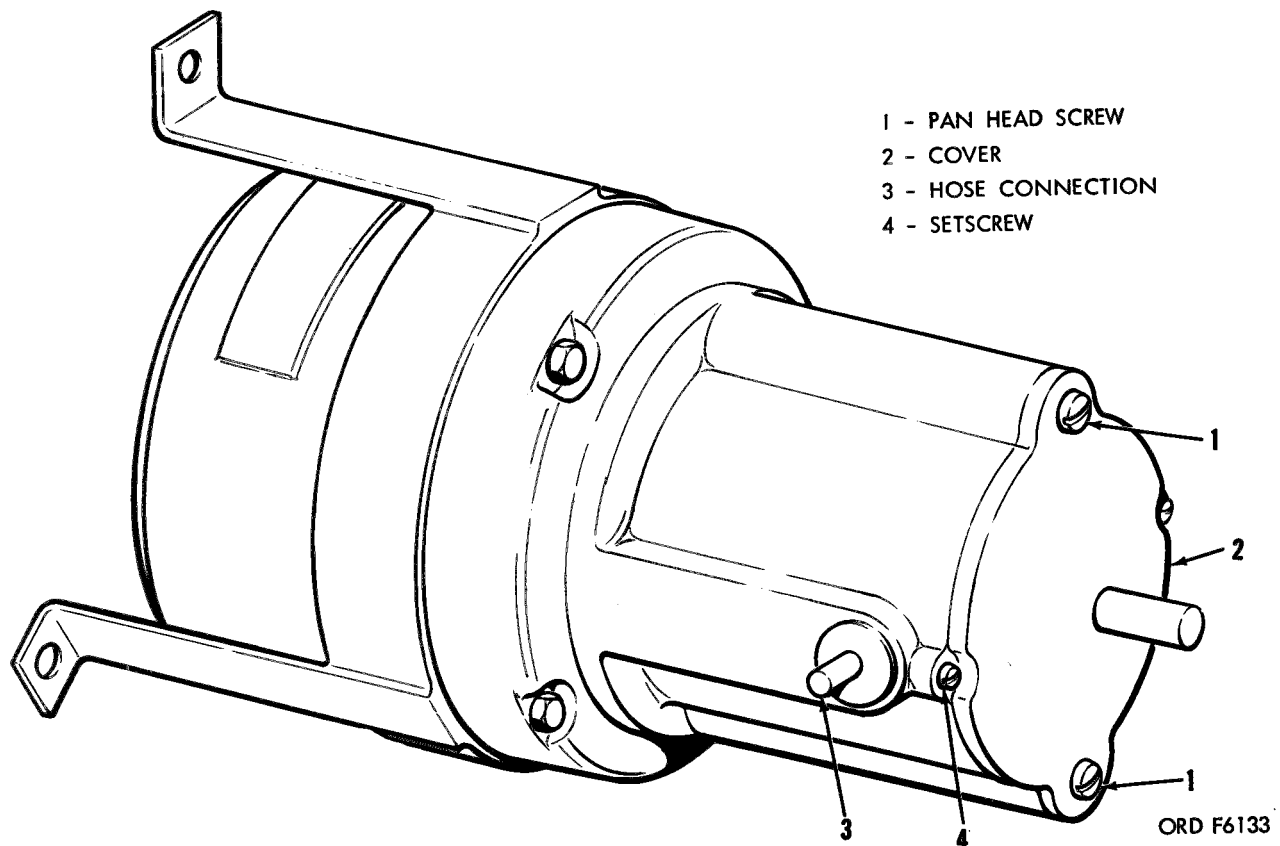

Figure 15. Vacuum pump.

- (3) Remove the two No. 6 x 5/8 thread-cutting tipping screws (1) bolting the cover (2) on the vacuum pump.
- (4) Apply several drops of SAE-20 oil on each of the two felt washers in the pump housing and secure the cover (2) on the vacuum pump with the two screws (1).
- (5) Connect the power cable (3A, fig. 4) to the power source and turn the power switch (3B, fig. 4) and pump switch (12, fig. 4) on.
- (6) Holding the hose connection (3) loosen the setscrew (4) on the left hand cylinder just enough to allow slight in and out movement of the cylinder.
- (7) Adjust the position of the cylinder in or out to allow maximum vacuum as shown on the vacuum gage (10, fig. 4) and tighten the setscrew (4).
- (8) Repeat the adjustment on the right hand cylinder as prescribed in (6) and (7) above.
- (9) Turn the vacuum pump control (9, fig. 4) counterclockwise until the vacuum gage (10, fig. 4) reads approximately 0.1 inch mercury and turn the vacuum pump switch (12, fig. 4) off.
- (10) Turn the power switch (3B, fig. 4) off and disconnect the power cable (3A, fig. 4) from the power source.

Caution: Do not pull the cylinder outward far enough to remove it from the housing since complete removal of the cylinder will make it necessary to repair the vacuum pump.

e. Installation. Place the tester in position in the case (1, fig. 4), align the screw holes, and secure control panel with the twelve No. 10 x 1/2 thread-cutting tapping screws (24, fig. 4).

CHAPTER 5

SHIPMENT AND ADMINISTRATIVE STORAGE AND DEMOLITION TO PREVENT ENEMY USE

Section I. SHIPMENT AND ADMINISTRATIVE STORAGE SHIPPING INSTRUCTIONS

69. Purpose

a. Responsibility. When shipping the tester, the unit commander will be responsible for shipping the materiel, including all tools and equipment, adequately processed, packaged, and packed to protect it from damage until it reaches the echelon of maintenance for required repairs; or in the case of troop movement, reaches its destination in a serviceable condition.

b. Army Shipping Documents. Prepare all army shipping documents in accordance with AR 725-50.

c. Preparation for Shipment. When the tester is removed from administrative storage for shipment it need not be reprocessed unless inspection reveals it to be inadequately preserved or when it is necessary because of anticipated in-transit weather or shipping conditions. Preservatives must not be removed or disturbed except as necessary to insure that the tester is complete and serviceable. If preservatives are removed, they must be restored prior to shipment.

70. Preservation, Packaging, Packing, and Marking Instructions

a. Preservation and Packaging. Preservation of the tester must be sufficient to protect it against deterioration and damage during shipment and administrative storage and/or the subsequent interval prior to use. Under no condition will tools and equipment with critical surfaces be packaged without benefit of sufficient preservation to assure adequate protection (TM 9-200). Preservation and packaging must be compatible with end use requirements.

b. Packing. Packed items must be ac-

ceptable to the carrier, while affording adequate protection to the items during shipment and administrative storage and/or the subsequent interval prior to use.

c. Marking. All materiel will be marked in accordance with TM 9-200.

71. Administrative Storage

a. General.

- (1) Unit commanders may, with the approval of major commanders, place the tester in administrative storage or return to supply agencies equipment that is beyond the maintenance capability of the unit. Testers must be stored in the most favorable location available, preferably one which affords protection from exposure to elements and pilferage.
- (2) All testers in administrative storage must be maintained so that they will be ready for immediate use and/or ready for shipment.
- (3) Administrative storage is restricted to a period of 90 days and must not be extended unless the tester is reprocessed.

b. Storage Procedures.

- (1) Perform a quarterly preventive-maintenance (PM) service on the tester. This maintenance will consist of inspecting, cleaning, servicing, and preserving, as required, and will also include minor repair parts replacement (if required) *not requiring* highly technical skills, or expensive, complicated, or bulky test equipment or tools.
- (2) Provide access to the tester to permit inspection, servicing, and removal from storage.

- (3) Mark the tester "Administrative Storage" (by use of tags or other convenient method). Testers so marked must not be operated while in this category.

c. Inspection in Administrative Storage. Visual inspection of the tester in administrative storage must be conducted at least

once each month to detect corrosion and rust. When corrosion and rust are found, corrective action must be taken immediately. A record of these inspections must be maintained for each tester in administrative storage. The records must be attached to the tester in such a manner as to protect them from the elements.

Section II. DEMOLITION OF MATERIEL TO PREVENT ENEMY USE

72. General

a. Destruction of the tester, when subject to capture or abandonment in the combat zone, will be undertaken by the using army only when, in the judgment of the unit commander concerned, such action is necessary in accordance with orders of, or policy established by, the army commander. When in the hands of maintenance personnel or in storage, destruction will be in accordance with FM 9-5 and the information below, when applicable.

b. The information which follows is for guidance only. Certain phases of the procedures outlined required the use of explosives and incendiary grenades which normally may not be authorized items of issue to the using organization. The issue of these and related materials and the conditions under which destruction will be effected are command decisions in each case, according to the tactical situation. Of the several means of destruction, those most generally applicable are:

Mechanical - Requires axe, pick mattock, sledge, crowbar, or similar implement.

Burning - Requires gasoline, oil, incendiary grenades, or other flammables, or welding or cutting torch.

In general, destruction of essential parts, followed by burning, will usually be sufficient to render the materiel useless. However, selection of the particular method of destruction requires imagination and resourcefulness in the utilization of the facilities at hand under the existing condition. Time is critical.

c. If destruction to prevent enemy use is resorted to, the materiel must be so badly

damaged that it cannot be restored to a usable condition in the combat zone either by repair or cannibalization. Adequate destruction requires that all parts essential to the operation of the materiel, be destroyed or damaged beyond repair. However, when lack of time and personnel prevents destruction of all parts, priority is given to the destruction of those parts most difficult to replace. Equally important, the same essential parts must be destroyed on like materiel, so that the enemy cannot construct one complete unit from several damaged ones.

d. If destruction by demolition or gunfire is directed, due consideration should be given to the observance of appropriate safety precautions.

73. Destruction of the Tester

a. Method No. 1 - Destruction by Mechanical Means.

- (1) Disconnect the tester from its power source.
- (2) Using an axe, pick mattock, sledge, or any other heavy implement, destroy the tester by smashing the meters, controls, and case.
- (3) Destroy the cables and vacuum hose by cutting them into short lengths.
- (4) Smash the work lamp, vacuum adapters, and collets. Elapsed time about 2 minutes.

b. Method No. 2- Destruction by Burning.

- (1) Using a welding or cutting torch, burn through the case and control panel and into the electrical devices. Burn and fuse the meter parts.

- (2) In absence of a welding or cutting torch, place piles of combustible material on and about the tester. Pour gasoline or oil over the combustible material and the tester, ignite by means of an incendiary grenade fired from a safe distance, by a combustible train of suitable length, or other appropriate means. Take cover immediately.

A hot fire is required to render the materiel useless. Elapsed time: about 2 minutes.

***Warning:* When igniting gasoline, due consideration should be given to the highly flammable nature of gasoline and its vapor. Carelessness in its use may result in fatal or painful burns.**

APPENDIX I

REFERENCES

1. General

a. Military Publications. The packaging publications listed herein are available to activities requiring publications. Requisition technical manuals, technical bulletins, supply manuals, and supply bulletins indexed in 310 series, DA Pam in accordance with AR 310-1.

b. Commercial Publications. Commercial publications listed herein maybe obtained from the following addresses: National Electrical Code; American Standards Association, 70 East 45th Street, New York 17, New York.

2. Army Regulations

Military Publications: General Policies	AR 310-1
Military Terms, Abbreviations, and Symbols: Authorized	AR 320-50
Safety Accident Reports and Records	AR 385-40
Department of the Army Requisitioning Receipt and Issue System	AR 725-50
Maintenance of Supplies and Equipment	AR 750-5
Dictionary of United States Army Terms	AR 320-5-1

3. Publications Indexes

The following publication indexes should be consulted frequently for latest changes or revisions of references given in the appendix and for new publications relating to materiel covered in this manual.

Index of Army Motion Pictures, Television

Recordings and Film strips	DA Pam 108-1
Index of Blank Forms... ..	DA Pam 310-2
Index of Training Publications	DA Pam 310-3

4. Field Manuals

Ordnance Direct Service Report	FM 9-3
Ordnance Service in the Field	FM 9-5
Military Training	FM 21-5
Techiques of Military Instruction.	FM 21-6
Military Symbols	FM 21-30

5. Forms

The following forms pertain to this manual:

- DD Form 6, Report of Damaged or Improper Shipment
- DD Form 1348, DOD Single Line Item Requisition System Document (Manual)
- DA Form 2028, Recommended Changes to DA Technical Manual Parts List of Supply
Manuals 7, 8, or 9
- DA Form 2404, Equipment Inspection and Maintenance Worksheet
- DA Form 2405, Maintenance Request Register
- DA Form 2407, Maintenance Request
- DA Form 2408-1, Equipment Daily or Monthly Log
- DA Form 2408-2, Lubrication Record

6. Other Publications

- a. General.*
The Army Equipment Record System and Procedures TM 38-750
- b. Cleaning.*
Trichloroethane, Technical (Methyl Chloroform) O-T-620
- c. Painting.*
Painting Instructions for Field Use TM 9-213
- d. Lubrication.*
Lubrication of Ordnance Materiel TM 9-273
- e. Processing, Packaging, and Packing.*
General Packaging Instructions for Ordnance General Supplies TM 9-200
- f. Storage.*
Protection of Ordnance General Supplies in Open Storage TB ORD 379
- g. Shipping.*
Department of the Army Requisitioning Receipt and Issue System AR 725-50

APPENDIX II

BASIC ISSUE ITEMS LIST

Section I. PREFACE

1. General

This appendix is a list of basic issue list items. It is composed of those items which make up the major end items of equipment and the first echelon tools, supplies, assemblies, and repair parts that are issued with the equipment and are required for stockage .

2. Requisition Notes

See appendix IV, paragraph 2.

3. Explanation of Columns

a. Source, Maintenance, and Recoverability Code (Col. 1).

- (1) *Materiel numerical codes (col. 1a).* This column indicates the responsible commodity command for the materiel. The commodity command responsible for supply of items in this list are:

Code	Type Materiel
9	Ordnance Materiel
10	Quartermaster Materiel

- (2) *Source (col. 1b).* This column indicates the selection status and source for the listed item. Source codes used in this list are:

Code	Explanation
C	Obtain through local procurement. If not obtainable from local procurement, requisition through normal supply channels with a supporting statement of nonavailability from local procurement.

- (3) *Maintenance level (col. 1c).* This column indicates the lowest maintenance echelon authorized to install the listed item. Maintenance level codes used in this list are:

Code	Explanation
O	Organizational maintenance (1st and 2d echelon).

- (4) *Recoverability (col. 1d).* This column indicates whether unserviceable items should be returned for recovery or salvage. When no code

is indicated, the item is expendable and not recoverable. Recoverability codes used in this list are:

Code	Explanation
R	Items which are economically repairable at field maintenance activities (3d and 4th echelon) and are normally furnished by supply on an exchange basis.

b. Federal Stock Number (Col. 2). This column indicates the Federal stock number which has been assigned by the Cataloging Division, Defense Logistics Services Center.

c. Description (Col. 3). This column indicates the Federal item name (shown in capital letters) and any additional description required for supply operation. The manufacturer's code and part number is also included for reference.

Code	Explanation
28500	Heyer Products Company Incorporated

d. Unit of Issue (Col. 4). This column indicates the quantity to be requisitioned.

e. Quantity Authorized (Col. 5). This column indicates the quantity of the listed item authorized for stockage to constitute the prescribed load.

f. Illustration. (Col. 6). This column indicates the figure number of the illustration that depicts the listed item. When more than one item appears on an illustration, the item number is also indicated.

4. Abbreviations

br	brass
c.	cycle
fl	flat
hdl	handle
hex	hexagon(al)
id	inside diameter
lb	pound
lg	long (length)
nom	nominal
oz	ounce
ru	rubber
sgle-ph	single phase
thd	thread
v	volt(s)
w/	with

5. Suggestions and Recommendations

The direct reporting of errors, omissions and recommendations for improving this technical manual by the individual user, is authorized and encouraged. DA Form 2028 will be used for reporting these improvements. This form may be completed using pencil, pen or typewriter. DA Form 2028 will be completed in triplicate and forwarded by the individual using the manual. The original

and one copy will be forwarded direct to:
Commanding General
Headquarters, U. S. Army Weapons
Command
ATTN: AMSWE-SMM-TE
Rock Island Arsenal
Rock Island, Illinois, 61202

One information copy will be provided to the individual's immediate supervisor (e.g., officer, noncommissioned officer, supervisor, etc.)

Section II. BASIC ISSUE ITEMS LIST

(1) Source, maintenance, and recoverability code				(2) Federal stock No.	(3) Description	(4) Unit of issue	(5) Quantity authorized	(6) Illustration	
(a) Material code	(b) Source	(c) Maintenance level	(d) Recoverability					(a) Figure No.	(b) Item No.
---	---	---	R	4910-393-2939	<p>MAJOR COMBINATION</p> <p>TESTER, ENGINE DISTRIBUTOR: bench type, 6, 12, and 24-volt distributors, sgle-ph, 60 c, 115 v (28500:168).</p> <p>COMPONENTS OF MAJOR COMBINATION</p> <p>None authorized</p> <p>SPARE PARTS</p> <p>None authorized.</p> <p>TOOLS AND EQUIPMENT FOR:</p> <p>TESTER, ENGINE DISTRIBUTOR: (28500:168)</p>	---	---	1	---
9	C	O	---	4910-356-7492	ADAPTER, ENGINE ELECTRICAL TEST, PRIMARY CIRCUIT: (distributor) w/spring loading through conductor plunger and male threaded connection.	ea	1	16	---
9	C	O	---	-----	CHUCK, DRIVE distributor, universal (28500:26043).	ea	1	16	---
9	C	O	---	-----	CLAMP, DISTRIBUTOR: universal (28500:26055).	ea	1	16	---
9	C	O	---	-----	COLLET AND BUSHING SET: (28500:26177) consisting of:	ea	1	16	---
					BUSHING, COLLET br, 11/16 id -----	ea	1	16	---
					BUSHING, COLLET: br, 7/8 id -----	ea	1	16	---
					COLLET ASSEMBLY : -----	ea	1	16	---
9	C	O	---	-----	COLUMN, DRIVE: (28500:26143-1) -----	ea	1	16	---
9	C	O	---	-----	COUPLING, DRIVE: ru (28500:20400) -----	ea	1	16	---
10	C	O	---	5120-242-7410	KEY, SOCKET HEAD SCREW: hex, L-hdl, 3/32 across fl, 2 nom arm lg.	ea	1	16	---
10	C	O	---	5120-240-5242	KEY, SOCKET HEAD SCREW: hex type, 1/8 across fl, L-type hdl, 2 nom lg arm lg.	ea	1	16	---
10	C	O	---	5120-198-5392	KEY, SOCKET HEAD SCREW: hex type, 5/32 across fl, L-type hdl, 2-1/2 nom lg arm lg.	ea	1	16	---
9	C	O	---	-----	KIT, ADAPTER, VACUUM: set of three fittings (28500 :21197) consisting of:	ea	1	16	---
					1/8 pipe thd				
					5/16-24 pipe thd				
					3/8-24 thd				
9	C	O	---	6635-449-3750	TESTER, SPRING RESILIENCY: portable designed to test tension type springs, weighting scale type, manually operated, hook load receiver, marked in oz, marked in lb, 0-5 lb range of graduations, 1/16 oz smallest increment.	ea	1	16	---
---	C	O	---	-----	WIRE, JUMPER: (28500:24323) -----	ea	1	16	---
---	C	O	---	-----	Work LAMP ASSEMBLY: (28500:31083) ---	ea	1	16	---
---	C	O	---	-----	WRENCH, CHUCK: (28500:31096) -----	ea	1	16	---

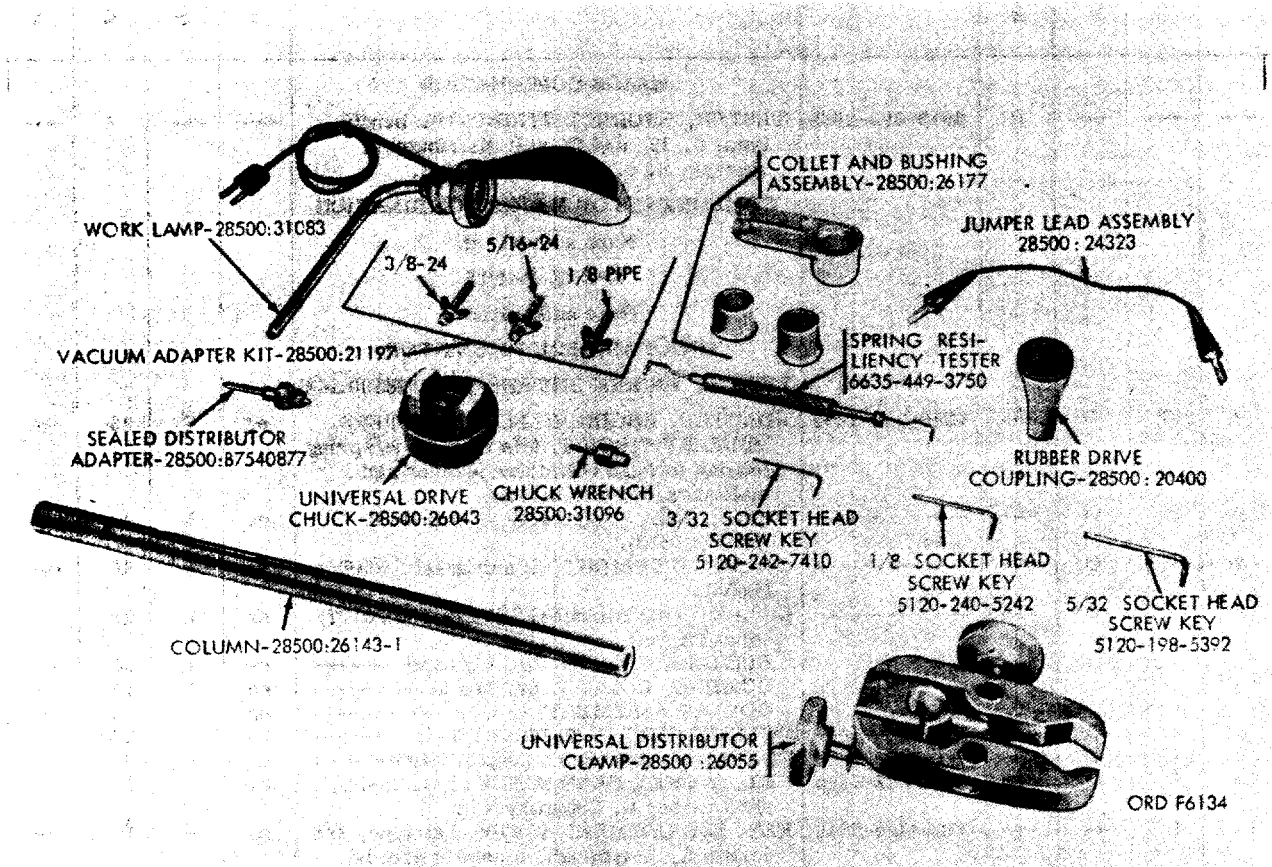

Figure 16. Tools and Equipment.

APPENDIX III

MAINTENANCE ALLOCATION CHART

1. Purpose

The maintenance allocation chart allocates specific maintenance operation to the proper level.

2. Basis

Allocation of maintenance operations is made on the basis of time, tools, and skills normally available to the various echelons in a combat situation and influenced by maintenance policy and sound maintenance practices as outlined in AR 750-5.

3. Explanation and Definitions

The maintenance allocation chart designates overall responsibility for the maintenance function of an end item or assembly. Repair and/or rebuild of major assemblies is designated by authority of the Army Commander representative, except for the specific subfunctions listed in the maintenance allocation chart. Deviations from maintenance operations allocated in the maintenance allocation chart is authorized only upon approval by the Army Commander representative.

SERVICE To clean, to preserve, and to replenish fuel and lubricants .

ADJUST To prevent or correct malfunction by maintaining prescribed limits or by bringing into proper or exact position.

INSPECT To verify serviceability and to detect incipient electrical or mechanical failure by scrutiny.

TEST To verify serviceability and to detect incipient electrical or mechanical failure by use of special equipment such as gages, meters, etc.

REPLACE To substitute serviceable assemblies, subassemblies, and parts for unserviceable components.

REPAIR To restore to a serviceable condition by replacing unserviceable parts, or by any other action required; utilizing tools, equipment, and skills available to include welding, riveting, straightening, adjusting, etc.

REBUILD To restore to a condition comparable to new by disassembling the item to determine the condition of each of its component parts and reassembling it using serviceable, rebuild, or new assemblies, subassemblies, and parts.

SYMBOL X The symbol X placed in the appropriate column indicates the echelon responsible for performing that particular maintenance operation but does not necessarily indicate that repair parts will be stocked at that level. Echelons higher than the echelons marked by X are authorized to perform the indicated operation.

*Maintenance Allocation Chart For
Tester, Engine Distributor (4910-292-2939)*

(1) Group No.	(2) Component and related operation	(3) 1st	(4) 2nd	(5) 3rd	(6) 4th	(7) 5th
	Tester, Engine Distributor					
	Inspect -----	X				
	Service -----	---	X			
	Adjust -----	X				
	Test -----	X				
	Repair -----	---	---	X		
	Rebuild -----	---	---	---	---	X
	Lead, Group					
	Inspect -----	X				
	Service -----	X				
	Repair -----	---	X			
	Replace -----	---	---	X		
	Vacuum Pump Group					
	Service -----	---	X			
	Adjust -----	---	X			
	Repair -----	---	---	X		
	Replace -----	---	---	X		

APPENDIX IV

REPAIR PARTS AND SPECIAL TOOL LISTS

Section I. PREFACE

1. General

a This appendix is a list of items which are required to be stocked by organizational maintenance units as their prescribed load. Also listed are additional repair parts which may be required for performing organizational maintenance but are to be requisitioned, as required, for immediate use only.

b. For prices of items of ordnance materiel, see the appropriate supply manual of the SM 9-2 series. Prices of items that are the responsibility of other commodity commands may be obtained from the appropriate type 2 supply manuals for those commands.

c. Additional application of items in this manual are listed in the supply manuals of the SM 9-3 series.

2. Requisition Notes

a. Repair Part Identified by Federal Stock Number.

- (1) If the exact item requisitioned is not furnished, or if other action is necessary, the exact nature of the action taken by the supply agency will be indicated by standard symbols on prescribed forms.
- (2) When requisitioning an item, the requesting agency will order the listed item. However, the supplying agencies will take necessary action to issue the exhaust stock item until stock is exhausted, whether it be an individual item, kit, set, or assembly.

b. Part to which FSN has not been assigned. When requisitioning a C source (local procurement) item identified only by a manufacturer's part number, it is mandatory that the following information be furnished the supply officer:

- (1) Manufacturer's code number (5

digit number preceding the colon in description column).

- (2) Manufacturer's part number (the number, and sometimes letters, following the colon, (1) above). Dashes, commas, or other marks must be included exactly as listed.
- (3) Noun name and dimensions if necessary.
- (4) Name of manufacturer of end item (from cover of TM or manufacturer's name plate).
- (5) Federal stock number of end item (from TM).
- (6) Manufacturer's model number (from TM or name/data plate, preferably name/data plate).
- (7) Manufacturer's serial number (from name/data plate).
- (8) Any other information such as type, frame number, and electrical characteristics, if applicable.
- (9) If DD Form 1348 is used, fill in all blocks except 4, 5, 6, and Remarks field in accordance with AR 725-50. Complete form as follows:
 - (a). In blocks 4, 5, and 6, list manufacturer's code, and manufacturer's part number (as listed in description column).
 - (b) In Remarks field, list noun name (repair part), end item application (FSN of end item), manufacturer, model number (end item) serial number (end item), and any other pertinent information such as frame number, type, etc.

3. Explanation of Columns

a. Source, Maintenance, and Recoverability Code (Col. 1).

- (1) *Materiel numerical codes (col. 1a).* This column indicates the responsible commodity command for the materiel. The commodity com-

mand responsible for supply of items in this list are:

<i>Code</i>	<i>Type Materiel</i>
3	Chemical Materiel
5	Engineers Materiel
9	Ordnance Materiel
10	Quartermaster Materiel
11	Signal Materiel

(2) **Source (col. 1b).** This Column indicates the selection status and source for the listed item. Source codes used in this list are:

<i>Code</i>	<i>Explanation</i>
C	Obtain through local procurement. If not obtainable from local procurement, requisition through normal supply channels with a supporting statement of nonavailability from local procurement.

(3) **Maintenance level (col. 1c).** This column indicates the lowest maintenance echelon authorized to install the listed item. Maintenance level codes used in this list are:

<i>Code</i>	<i>Explanation</i>
O	Organizational maintenance (1st and 2d echelon).

(4) **Recoverability (col. 1c).** This column indicates whether unserviceable items should be returned for recovery or salvage. When no code is indicated, the item will be considered expendable. Recoverability codes in this list are:

<i>Code</i>	<i>Explanation</i>
R	Items which are economically repairable at field maintenance activities (3d and 4th echelon) and are normally furnished by supply on an exchange basis.

b. Federal Stock Number (Col. 2). This column indicates the Federal stock number which has been assigned by the Cataloging Division, Defense Logistics Services Center.

c. Description (Col. 3). This column indicates the Federal item name (shown in capital letters) and any additional description required for supply operations. The manufacturer's code and part number is also included for reference.

<i>Code</i>	<i>Explanation</i>
28500	Heyer Products Company Incorporated

d. Unit of Issue (Col. 4). This column indicates the quantity to be requisitioned.

e. Quantity Incorporated in Unit (Col. 5).

This column indicates the total number of times the listed item is used in the end item (major item) or major combination. Where no quantity is shown, reference should be made to the first appearance of the item as indicated in the "description" column.

f. 15-Day Maintenance Allowance (Col.

6). This column indicates the quantitative allowance for second echelon of the listed item. These allowances represent one prescribed load, for a 15-day period, for the number of major items supported. They must be on hand or on order at all times. Major commanders will determine the number of prescribed loads second echelon units will carry. Units and organizations authorized additional prescribed loads will multiply the number of equipments supported by the number of prescribed loads. Additional repair parts which maybe required for performing authorized maintenance, but are not authorized for stockage in the prescribed load, are indicated by an asterisk (*). These items are to be requisitioned as required for immediate use only. Where no quantity is shown, reference should be made to the first appearance of the item as indicated in the "Description" column.

Note. The 15-day level is not applicable to special tools for organizational maintenance.

g. Illustrations (Col. 7). This column indicates the figure number of the illustration that depicts the listed item.

4. Abbreviations and Symbol

a. Abbreviations

amp	ampere(s)
btry	battery
cd	cadmium
cntr	container
cop	copper
deg	degree(s)
dr	drum
ea	each
F	Fahrenheit
Fed	Federal
fil	filament
fin	finish
flex	flexible
ga	gage
gal	gallon(s)
gr	grade
h.	high (height)
hr	hour(s)

id	inside diameter
in.	inch(es)
lb	pound
lg	length (long)
lt	light(weight)
max	maximum
med	medium
min	minimum
mtl	metal
od	outside diameter(s)
opng	opening
oz	ounce
pltd	plated
pt	point
ru	rubber
qt	quart(s)
ro	roll
S.	steel
scr	screw
sq	square
str	straight
term.	terminal
thk	thick(ness)
v	volt(s)
w	wide, width
w/	with
yd	yard(s)
<i>b. Symbol.</i>	
≠	as required

5. Suggestions and Recommendations

The direct reporting of errors, omissions and recommendations for improving this technical manual by the individual user, is authorized and encouraged. DA Form 2028 will be used for reporting these improvements. This form may be completed using pencil, pen or typewriter. DA Form 2028 will be completed in triplicate and forwarded by the individual using this manual. The original and one copy will be forwarded direct to:

Commanding General
Headquarters, U. S. Army Weapons
Command
ATTN: AMSWE-SMM-TE
Rock Island Arsenal
Rock Island, Illinois, 61202

One information copy will be provided to the individual's immediate supervisor (e. g., officer, noncommissioned officer, supervisor, etc.)

Section II. REPAIR PARTS AND SPECIAL TOOL LISTS

(1) Source, maintenance, and recoverability code				(2) Federal stock No.	(3) Description	(4) Unit of issue	(5) Quantity incorporated in unit	(6) 10-day maintenance allowance per 1000 units	(7) Illustration	
(a) Material code	(b) Source	(c) Maintenance level	(d) Recoverability						(a) Figure No.	(b) Item No.
					REPAIR PARTS FOR:					
9	---	--	R	491 0-392-2939	TESTER, ENGINE DISTRIBUTOR: (28500:168).					
11	C	O	---	5975-383-1318	CABLE NIPPLE, ELECTRICAL: ru or plastic, flex, str-type, 13/64 max od cable, 2-37/64 lg, 41/64 id, black.	ea	3	*	4	
11	C	O	---	5940-186-8929	CLIP, ELECTRICAL: btry-style, 5/8 max jaw opng, cop, uninsulated, 3/8 h, 2-7/16 lg, 1/2 w, 40 amp, 1 scr type term.	ea	1	*	4	
9	C	O	---	5940-621-3276	CLIP, ELECTRICAL: btry-style, 1/2 max jaw opng, S, cd-pltd fin, uninsulated, 1/16 h, 2-7/16 lg, 1/4 w, 20 amp, 1 scr type term.	ea	2	*	4	
5	C	O	---	6240-155-8634	LAMP, INCANDESCANT: 115-v, 50-watt, 1C-22 tungsten fil, rough service, med scr base, A19 bulb, inside frosted, white light, lamp, 50 A/RS.	ea	1	1	---	
					CLEANING AND PRESERVING MATERIALS					
5	---	---		8020-597-4770	BRUSH, PAINT: fl, hog bristle, w/sq edge, 3 w, 7/8 thk, 3-1/8 min exposed lg, H-B-420, class 1, gr B, size 3 in.	ea	---	≠	---	---
9	---	---	---	6850-598-3057	CLEANING COMPOUND, SOLVENT: alkali type, Fed P-C-436a	lb	---	≠	---	---
9	---	---	---	6850-224-6661	35 lb pail ----- 100 lb dr -----	lb	---	≠	---	---
9	---	---	---	6850-224-6665	CLEANING COMPOUND, SOLVENT: self-emulsifying, MIL-S-11090	gal	---	≠	---	---
9	---	---	---	6850-224-6666	5 gal cntr -----	gal	---	≠	---	---
10	---	---	---	7930-249-8036	DETERGENT, PAINT SURFACE: powdered, used for general cleaning Fed P-C-431a, type I, 5 lb pail.	lb	---	≠	---	---
					DRY CLEANING SOLVENT: liquid form, to remove soil from surfaces in dry cleaning process, petroleum distillate, 140 deg F flash pt, Fed P-S-661, type II.					
10	---	---	---	6850-281-1986	55 gal dr (16 ga)-----	gal	---	≠	---	---
10	---	---	---	6850-285-8011	55 gal dr (18 ga)-----	gal	---	≠	---	---
10	---	---	---	6850-637-6135	bulk -----	gal	---	≠	---	---
					ENAMEL: full gloss, 8 hr max air dry hard time, gray color no. 16187 Fed TT-E-489, class A.					
5	---	---	---	8010-298-2300	1 qt can -----	can	---	≠	---	---
5	---	---	---	8010-286-7731	1 gal can -----	gal	---	≠	---	---
5	---	---	---	8010-286-7749	5 gal pail -----	gal	---	≠	---	---
					LUBRICATING OIL: general purpose, MIL-L-15016, symbol 3042.					

(1) Source, maintenance, and recoverability code				(2) Federal stock No.	(3) Description	(4) Unit of issue	(5) Quantity incorporated in unit	(6) 15-Day maintenance allowance per 100 equipments	(7) Illustration	
(a) Materiel code	(b) Source	(c) Maintenance level	(d) Recoverability						(a) Figure No.	(b) Item No.
CLEANING AND PRESERVING MATERIALS — Continued										
LUBRICATING OIL: — Continued										
9	---	---	---	9150-235-9065	5 gal dr ----- PRIMER, COATING: 30 min max air drying time for recoating Fed TT- P-664.	gal	---	≠	---	---
5	---	---	---	8010-161-7274	1 gal can -----	gal	---	≠	---	---
5	---	---	---	8010-161-7275	5 gal can ----- RAG, WIPING: cotton, sterilized, unbleached, white, designed for general purpose use, Fed DDD-R- 30, class II.	gal	---	≠	---	---
10	---	---	---	7920-234-8462	5 lb bag -----	lb	---	≠	---	---
10	---	---	---	7920-205-1711	50 lb bale ----- REMOVER, PAINT: alkali-organic solvent, nonflammable, liquid, 50 gal in a 55 gal agitator dr, MIL-R- 12294.	lb	---	≠	---	---
5	---	---	---	8010-283-0511	5 gal cntr -----	gal	---	≠	---	---
5	---	---	---	8010-283-7719	55 gal dr -----	gal	---	≠	---	---
5	---	---	---	8010-227-1693	REMOVER, PAINT: alkali (ferrous mtl) Fed TT-R-230, class I, 400 lb dr.	lb	---	≠	---	---
5	---	---	---	8010-227-1694	REMOVER, PAINT: alkali (nonferrous mtl) Fed TT-R-230, class II, 400 lb dr. TAPE, PRESSURE, SENSITIVE AD- HESIVE: cellulose backing, trans- parent, 3 in. od of core, Fed PPP- T-60, type III, class 2, clear, 72 yd lb.	gal	---	≠	---	---
10	---	---	---	8135-663-3732	1 in. w -----	ro	---	≠	---	---
10	---	---	---	8135-266-6715	2 in. w -----	ro	---	≠	---	---
10	---	---	---	8135-281-2700	3 in. w -----	ro	---	≠	---	---
5	---	---	---	8010-242-2089	THINNER, PAINT, MINERAL SPIRITS: 340 deg F to 485 deg F distillation range, Fed TT-T-291a, It type thinner, 1 gal can. TRICHLOROETHANE, TECHNICAL: (methyl chloroform) (O-T-620).	gal	---	≠	---	---
3	---	---	---	6810-664-0387	1 gal can -----	gal	---	≠	---	---
3	---	---	---	6810-664-0275	5 gal can -----	gal	---	≠	---	---

I N D E X

	Paragraphs	Page		Paragraphs	Page
Abbreviations	App II, IV	35,40	Method No. 2	73b	31
Accident, report of	3d	3	Direction control switch.	21	9
Adjustment (vacuum pump)	68d	28	Disassembly and assembly instructions	54a	23
Administrative storage	71	30	Dwell meter	16	8
General	71a	30	Electrical clips and electrical cable nipples:		
Inspection	71c	31	Cleaning and inspection	64c	27
Storage procedures	71b	30	Description	63	27
Allocation chart (maintenance)	App III	39	General	64a	27
Army regulations	App I	33	Installation	64e	27
Army shipping documents	69b	30	Maintenance	64	27
Authorized forms	3b	3	Removal	64b	27
Basic issue items list	App II	35	Repair	64d	27
Cam angle adjustment	17	8	Equipment improvement recommendations	3 c	3
Cam angle lead	15	8	Field manuals	App I	33
Cam angle test	30	11	Field report of accidents	3d	3
Fly-ball governor spark advance	32	14	Fly-ball governor spark advance	33	14
vacuum controlled spark advance	31	14	Forms	App I	33
Cautions and identifying marks	5	4	Forms, records, and reports	3	2
Cleaning	44	19	Authorized forms	3b	3
Electrical parts	44a(2)	19	Field report of accidents	3d	3
General	44a	19	General	3a	2
Metal parts	44a(1)	19	Equipment improvement recommendations	3 c	3
Precautions	44b	20	General cleaning precautions	44	19
Rust removal	44c	20	General disassembly and assembly instructions	54a	23
Cleaning and preserving materials	App IV	40	Installation	9c	5
Coil leads	13	8	Introductions (general):		
Commercial publication	App I	33	Scope	1	2
Common tools and equipment.	52	23	Inspection in administrative storage	71c	31
Controls and instruments:			Inspection on receipt of materiel	9e	5
115-volt electrical receptacle	12	8	Lubrication	54	23
Cam angle adjustment	17	8	General disassembly and assembly instructions	54a	23
Cam angle lead	15	8	Points of application	54b	23
Coil leads	13	8	Reports and records	54c	23
Direction control switch	21	9	Lubrication and painting:		
Dwell meter	16	8	Lubrication, organizational	54	23
General	10	8	Painting	55	23
Meter selector	18	8	Maintenance allocation	2	2
Motor reset button	14	8	Operator maintenance allocation	2a	2
Power cable and power switch	11	8	Organizational.	2b	2
Speed control	22	9	Maintenance allocation chart.	App II	35
Speed range selector switch	20	8	Metal parts, cleaning of	44a(1)	19
Tachometer indicator	19	8	Meter selector	18	8
Vacuum gage	24	9	Military publications	App I	33
Vacuum hose	23	9	Motor reset button.	14	8
Vacuum pump control	26	9			
Vacuum pump switch.	25	9			
Data plates	6	4			
Definitions of terms, pre- ventative maintenance.	App I	33			
Demolition of materiel (general)	72	31			
Description and data	4	3			
Destruction of the tester	73	31			
Method No. 1	73a	31			

	Paragraphs	Page		Paragraphs	Page
Operation (general)	27	9	Repair parts	37	1 8
Mounting instructions (general)	9c	5	Special tools and equipment	39	1 8
Operating instructions	8	5	Requisition notes	App II	3 5
Purpose	8a	5	Rust removal	44c	2 0
Services	9	5	Scope	1	2
Operation	29	10	Services	9	5
Controls	29e	11	Cleaning	9b	5
General	29a	10	Inspection	9e	5
Mounting governor	29c	11	Installation	9c	5
Mounting instructions	29b	11	Lubrication	9d	5
Vacuum controlled distributors	29d	11	Unpacking and checking	9a	5
Operator maintenance			Service upon receipt of materiel:		
instructions (general)	36	18	Purpose	8	5
Operator preventive maintenance			Shipment and storage:		
services (general)	40	18	Army shipping documents	69b	30
Other publications	App I	33	Preparation for shipment	69c	30
Painting	55	23	Purpose	69	30
Points of application.	54b	23	Responsibility.	69a	30
Power cable and power switch . .	11	8	Synchronizing points	34	14
Preparation for operation	28	9	Double coil		
Preparation for shipment	69c	30	Double breaker arm		
Preservation, packaging, pack-			Vertical type distributors		
ing and marking instructions	70	30	Tables:		
Marking	70c	30	Preventive maintenance checks		
Packing	70b	30	and services (table I)	46	20
Preservation and packing . .	70a	30	Preventive maintenance checks		
Preventive maintenance service	45	20	and services (table II)	49	21
Cleaning	44	19	Troubleshooting (table III) . . .	59	26
Definition of terms	App III	39	Troubleshooting (table IV) . . .	62	26
Electrical parts	64	27	Tabulated data.	7	4
General	58	25	Tachometer indicator	19	8
Metal-parts, cleaning of.	44a(1)	19	Tester (shutting down after use)	35	16
Organizational	26	9	Troubleshooting:		
Plates	58c	25	Procedure	49	21
Precautions, cleaning	44b	20	Purpose	47	21
Procedures	58	25	Scope	48	21
Purpose	57	25	Unpacking and checking	9a	5
Recording repairs	57	25	Vacuum controlled spark advance	33	14
Responsibility.	41	18	Vacuum gage	24	9
Rust removal	44c	20	Vacuum hose	23	9
Services	58d	25	Vacuum pump control	26	9
Procedures (general)			Vacuum pump switch	25	9
1st echelon	46	20	Vacuum control spark advance		
2d echelon	59	26	(cam lobe tests)	33	14
References	App I	33	Vacuum pump:		
Repair parts, tools, and equip-			Adjustment	68d	28
ment (organizational mainte-			Description	67	28
nance instructions):			General	68a	28
Common tools and			Installation	68e	29
equipment	52	23	Maintenance	68	28
General	50	23	Removal	68b	28
Lubrication	54	23	Work lamp:		
Repair parts	51	23	Description.	65	28
Special tools and equipment	53	23	General	66a	28
Reports and records	54c	23	Inspection	66c	28
Repair parts, tools, and equip-			Installation	66d	28
ment (operator maintenance			Maintenance	66	28
instructions):			Removal	66b	28
General	36	18			
Common tools and equipment	38	18			

By Order of Secretary of the Army:

EARLE G. WHEELER,
*General, United States Army,
Chief of Staff.*

Official:

J. C. LAMBERT,
*Major General, United States Army,
The Adjutant General.*

Distribution:

Active Army:

DCSLOG (1)	TC Stg Sta, Camp Kilmer (1)
CNGB (1)	TC Stg Sta, Ft Hamilton (1)
CofEngrs (4)	TC Stg Sta, Ft Dix (1)
OCofSptS (2)	TC Stg Sta, Ft Devens (1)
CSigO (1)	TC Stg Sta, Camp Leroy Johnson (1)
USAOCDA (1)	TC Stg Sta, Camp A. P. Hill (1)
USAARMBD (2)	TC Stg Sta, Ft Bragg (1)
USAAVNBD (1)	TC Stg Sta, Camp Pickett (1)
USAARTYBD (1)	TC Stg Sta, Ft Benning (1)
USARADB (1)	ARMISH (3)
USAATBD (2)	Units org under fol TOE:
USCONARC (3)	5-600 (2)
USAMC (5)	5-605 (2)
USASCOM (6)	5-607 (2)
USAWECOM (60)	6-635 (2)
USA Avn & Sur Mat Comd (10)	9-7 (2)
ARADCOM (2)	9-9 (2)
ARADCOM Rgn (2)	9-25 (2)
OS Maj Comd (1) except	9-26 (2)
USAREUR (10), USASETAF (6)	9-65 (2)
USARSOUTHCOM (3), USARYIS (2)	9-66 (2)
OS Base Comd (2)	9-67 (2)
LOGCOMD (3)	9-75 (2)
Armies (3) except	9-127 (2)
Fourth US Army (2)	9-167 (2)
Fifth US Army (3)	9-197 (2)
Sixth US Army (1)	9-217 (2)
EUSA (5)	9-357 (2)
Div (2)	10-445 (2)
USMA (2)	10-448 (2)
USA Ord Sch (2)	29-1 (2)
USAAMS (2)	29-11 (2)
USAQMS (2)	29-15 (2)
USAARMS (4)	29-16 (2)
Army Dep (1) except	29-17 (2)
Mt Rainer (2)	29-21 (2)
Letterkenny (2)	29-25 (2)
Arsenals (2) except	29-26 (2)
Raritan (10)	29-27 (2)
Detroit (5)	29-35 (2)
USAEPG (1)	29-36 (2)
APG (1)	29-37 (2)
Dugway PG (1)	29-41 (2)
Yuma PG (1)	29-51 (2)
USA Engr Cen (2)	29-55 (2)
Ft Monmouth (2)	29-56 (2)
Springfield Armory (1)	29-65 (2)
Brooklyn Army Tml (1)	29-66 (2)
Ft Story (1)	29-75 (2)
TC Tng Comd Comd, Ft Eustis (2)	29-79 (2)

29-85 (2)
29-86 (2)
29-105 (2)

29-109 (2)
29-311 (2)
39-61 (2)

NG: State AG (3).

USAR: Units—Same as Active Army except allowance is one copy to each unit.
For explanation of abbreviations used, see AR 320-50.

☆ U.S. GOVERNMENT PRINTING OFFICE: 1991 - 281-486/42180

